

Clause-internal successive cyclicity: phasality or intervention?

Stefan Keine

UCLA

Hedde Zeijlstra

Universität Göttingen

Abstract: The well-known requirement that movement must proceed successive-cyclically through intermediate landing sites is standardly attributed to the presence of locality domains (phases) along the extraction path. Correspondingly, the existence of clause-medial intermediate landing sites is commonly taken as evidence for the existence of a clause-medial phase. In this paper, we argue that successive cyclicity through clause-medial positions is better understood as the result of intervention by the external-argument DP, not phasehood. The argument is based on three case studies that involve morphological reflexes of successive cyclicity: (a) *meN*-deletion in Indonesian, (b) *ké*-morphology in Dinka, and (c) *kè*-morphology in Defaka. Building on recent proposals about the principles that govern the behavior of complex probes, we propose that C in these languages can only attract the closest element. Elements separated from C by an intervening DP must first “leapfrog” around the intervener, resulting in successive-cyclic movement. Evidence for this shift away from absolute locality domains like clause-medial phases to a DP-intervention account includes: (a) the reflexes of successive cyclicity are selective, arising with some elements but not others, (b) the height of the intermediate landing site differs across languages and coincides with the canonical subject position in these languages, (c) some elements that are VP-external show the effect, and (d) movement from the same position may or may not be successive-cyclic, depending on whether a higher DP intervenes. Our account represents a shift away from rigid locality domains like clause-medial phases and raises the possibility that clause-medial phases can be dispensed with.

1. Introduction

According to standard phase theory (Chomsky 2000, 2001, 2008), syntactic structure is subject to periodic Spell-Out (or Transfer), which renders it unavailable for further syntactic processes (the Phase Impenetrability Condition or PIC).¹ This notion of phase does not, in and of itself, determine which domains count as phasal (and equivalently, which heads constitute phase heads). The question is empirical in nature. The traditional view (Chomsky 2000, 2001 and much subsequent work) holds that CPs and (transitive) vPs are phases, at least in the verbal domain, but a number of alternatives have been explored in the literature, including that every phrase is a phase (Bošković 2002, Boeckx 2003, Müller 2004, 2010, 2011, Boeckx and Grohmann 2007; see also Manzini 1994 and Takahashi 1994), that every syntactic operation constitutes a phase (Epstein and Seely 2002), that phasehood is determined contextually (Bošković 2005, 2014, Den Dikken 2007, Gallego and Uriagereka 2007a,b, Takahashi 2010, 2011), and that CP is a phase but vP is not (Grano and Lasnik

¹ There exist at least two widely adopted versions of the PIC. One is that the phase complement is spelled out once the next-higher head is merged (Chomsky 2000); the other is that Spell-Out takes place when the next-higher *phase* head is merged (Chomsky 2001). We will tentatively assume the former version here but our key claim that vP is not a phase at all is not specifically tied to one choice over the other.

2018, Keine 2020a,b, Mendes and Ranero 2021). Across these proposals, there is broad (though not universal, see Den Dikken 2017) consensus that CP is a phase, a view that goes back to Chomsky (1973, 1977, 1981). But the identity and distribution of other phase heads (e.g., vP, DP, PP) is less securely established and hence more controversial.

In this paper, we focus on the status of clause-internal phases (as opposed to clause-peripheral phases like CP). It is standardly assumed, following Chomsky (2000, 2001), that clauses contain a clause-medial phase, typically taken to be vP (an idea that goes back to Chomsky 1986). Important empirical motivation for this view comes from clause-internal intermediate landing sites of movement, as shown in (1).

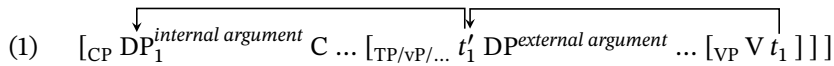

As with every issue in locality, we can think of the requirement that underlies the intermediate landing site in (1) either in terms of *absolute domains* or in terms of *intervention/minimality*. The phase-based analysis amounts to the former: there exists a clause-internal absolute locality domain (i.e., vP), which enforces movement through its edge. A conceivable alternative approach is in terms of intervention by the external argument DP: the external argument DP intervenes between C and the internal argument DP and thereby blocks attraction. The internal argument must therefore move to a position above the external argument—so-called “leapfrogging” (see Bobaljik 1995, McGinnis 1998, and Branan 2021)—in order to be closer to C. These two approaches as stated in general terms in (2).

- (2) a. *Domain/phase-based approach:*
 Obligatory successive-cyclic movement through a clause-internal position is the result of a clause-internal phase.
- b. *DP-intervention approach:*
 Obligatory successive-cyclic movement through a clause-internal position is the result of leapfrogging around an intervening DP.

While clause-internal intermediate landing sites have predominantly received domain-based accounts that fall under (2a), recent work on the locality of \bar{A} -dependencies in other domains paves the way for an analysis in terms of DP intervention in line with (2b). This work has argued that \bar{A} -probes may be specified in such a way that they may only attract the structurally closest DP (Aldridge 2004, 2008a, Rackowski and Richards 2005, Branan and Erlewine 2021, Coon et al. 2021):

- (3) *\bar{A} -attraction of the closest DP*
 An \bar{A} -probe can be specified to only attract the structurally closest DP.

(3) may be implemented in several ways, to which we will return in section 2 and beyond. The original motivation for (3) comes from movement restrictions unrelated to successive cyclicity. But (3) also suggests a potential account of successive cyclicity: in order for a lower DP to be attractable by C, it must first leapfrog over every intervening DP, resulting in a successive-cyclic derivation.

In this paper, we investigate clause-internal morphological reflexes of successive-cyclic movement with respect to these two approaches. In particular, we focus on (i) *meN*-deletion in Indone-

sian in section 2, (ii) *ké*-morphology in Dinka in section 3, and (iii) *kè*-morphology in Defaka in section 4. All of these patterns have been taken as crucial evidence for vP phasehood in the previous literature. Our goal is to assess to what extent they are amenable to a DP-intervention account based on (3). We will argue that not only is an analysis in terms of (3) possible, such an analysis also provides a better empirical fit. First, across these case studies, the position of the morphological reflex tracks the surface position of the external argument. This follows on a DP-intervention account but not on a phase-based analysis. Second, we show that the relevant morphology arises only in the presence of an intervener of the right “kind” (to be made more precise). Because the nature of the intervener plays a central role on the intervention account but not the phase account, the former offers a more principled explanation of this observation.

The general conclusion we draw is that successive cyclicity does not entail phasehood. DP intervention may give rise to superficially similar effects as phases, and care must be taken to differentiate between the two. If there is evidence that at least some instances of successive cyclicity through a clause-internal position are the result of DP intervention, a more general question that then arises is whether there are cases that still require an analysis in terms of phases or whether clause-internal phases may be dispensed with altogether. In section 5, we discuss several other traditional arguments for clause-internal phases (in particular vP phases), and we argue that they do not, after all, provide evidence for phasehood. We also demonstrate a number of systematic asymmetries between CPs and vPs phase that are unexpected, all else equal, if both CPs and vPs are phases but that receive a principled explanation if CP is a phase but vP is not. Taken together, these considerations raise the possibility that only clause-peripheral projections (i.e., CPs) (or edges of extended projections like CPs and DPs, see Bošković 2014 for discussion) are phases but clause-internal projections (in particular vPs) are not (Grano and Lasnik 2018, Keine 2020a,b, Mendes and Ranero 2021, Poole 2022). Apparent effects of clause-internal phases are better attributed to other syntactic factor.

Before we proceed, we would to mention that all the empirical patterns we focus on here involve a subject/object asymmetry in the sense that object extraction causes the morphological reflex but local subject extraction does not. This asymmetry is often the key motivation for analyzing the pattern in terms of clause-internal (in particular, vP) phases. We will put aside empirical patterns that treat \bar{A} -movement of all DPs the same as these can be analyzed purely with reference to CP. As such, they do not unambiguously diagnose a clause-internal intermediate landing site and are therefore not clearly relevant for the choice between (2a) and (2b).²

² For example, in Passamaquoddy, \bar{A} -movement of any DP over a verb allows this verb to optionally appear in an agreeing participial form. And while this behavior has been analyzed in terms of vP phases (Bruening 2001, 2004) and sometimes been taken as evidence for vP phases (Van Urk 2016, 2020a,b), it seems equally possible to us to locate the effect in CP, with the added assumption that an effect in C may morphologically manifest on the verb (a standard syntax–morphology mismatch, familiar from, e.g., affix lowering in English).

Another instance of a morphological reflex that treats subject and objects alike is tonal marking in Asante Twi (Korsah and Murphy 2020). Here, the evidence is that the effect is syntactically quite high (in particular, it is (i) higher than the base position of the external argument, (ii) higher than adjunct PPs, (iii) higher than negation, and (iv) higher than progressive and perfective aspect), making a CP analysis at least viable. We note that Korsah and Murphy (2020) do argue that the effect is not as high as C, based on the generalization that the verb, negative prefix, and aspect undergo the tone shift, but tense suffixes and agreement prefixes do not. However, contra to Korsah and Murphy’s (2020) generalization, Marfo (2005a, 2005b:164–166) shows that the tone shift does spread onto agreement prefixes under the right circumstances and that the cases in which the tone does not spread is phonologically conditioned (the tone cannot

The paper proceeds as follows: Sections 2–4 contain our core case studies: Section 2 investigates *meN*-deletion in Indonesian; section 3 discusses *ké*-morphology in Dinka; and section 4 discusses *kè*-morphology in Defaka. Across these three case studies, we argue that these morphological reflexes of successive cyclicity are better understood in terms of DP intervention rather than clause-medial phasality. Based on this conclusion, section 5 then addresses the question whether there is still motivation for clause-medial phasality, or whether absolute locality can more generally be replaced by relative locality. While our discussion there is necessarily tentative, we argue that this now becomes a real possibility.

2. *MeN*-deletion in Indonesian

Our first case study is based on deletion of the active-voice prefix *meN*- under \bar{A} -movement in Standard Indonesian and a dialect of Malay used by educated speakers in Singapore. The basic pattern is that the active voice prefix *meN*- is obligatorily deleted if a DP other than the local subject undergoes \bar{A} -movement over it (Saddy 1991, Cole and Hermon 1998, Soh 1998, Fortin 2006, Aldridge 2008b, Cole et al. 2008, Sato 2012, Georgi 2014, Jeoung 2018). Aldridge (2008b), Cole et al. (2008), Sato (2012), Georgi (2014), and Jeoung (2018) all interpret this pattern as evidence for vP phases. While their respective accounts differ substantially, the guiding analytical intuition is that any non-local subject DP must move to the vP phase edge on its way to [Spec,CP], and this movement to [Spec,vP] bleeds *meN*-. We argue instead that these facts are better understood in terms of intervention instead of domain locality. Specifically, while we follow the view that *meN*-deletion is a reflex of an intermediate landing site in the vP domain, we will argue that this intermediate landing site is not the consequence of vP phasehood but is better understood as the result of intervention by the local subject. This, we conclude, favors an account in terms of minimality rather than phases.

2.1. The pattern

Standard Indonesian has an active-voice marker *meN*- (where *N* can take different context-dependent phonological shapes). According to some authors, *meN*- is optional in sentences that allow it (see Georgi 2014:53—who cites Macdonald and Darjowidjojo 1967:238—, Fortin 2006:48, and Jeoung 2018:ch. 3 for Indonesian; and Cole and Hermon 1998:231, Soh 1998:295–297, and Soh and Nomoto 2009:150 for Malay), while other authors describe *meN*- as obligatory if it is possible (Cole et al. 2008:1504, Sato 2012:43). This seems to be a matter of dialectal or register variation (Soh 1998:296, Cole et al. 2008), which we put aside here. What we will focus on here is configurations in which *meN*- becomes impossible.

In the baseline example (4a), the verb bears the prefix *meN*-. Crucially, when a DP other than the local subject undergoes \bar{A} -movement, *meN*- is obligatorily deleted, as illustrated with object movement in (4b). If the local subject undergoes movement, *meN*- does not need to delete (4c).

spread across an onset). As far as we can tell, this purely phonological account covers Korsah and Murphy's (2020) cases, and so no appeal to a clause-internal landing site or vP phases is necessary to account for them.

- (4) a. *Baseline*
 Ali telah **mem**-baca buku itu.
 Ali PFV ACT-read book the
 ‘Ali has read the book.’ [Soh 1998:296, ex. (6)]
- b. *Object extraction*
Apa-kah₁ yang Ali telah (***mem**-)baca ___₁?
 what-Q that Ali PFV (***ACT**-)read
 ‘What has Ali read?’ [Soh 1998:297, ex. (9b,c)]
- c. *Subject extraction*
Apa-kah₁ yang ___₁ telah **mem**-baca buku itu?
 who-Q that PFV ACT-read book the
 ‘Who has read the book?’ [Soh 1998:297, ex. (9a)]

In constructions with two DP objects, \bar{A} -movement of either bleeds *meN*-.

- (5) *\bar{A} -movement in ditransitive constructions*
- a. **Apa**₁ yang kamu (***mem**-)beli-kan ibu-mu ___₁?
 what that you (***ACT**-)buy-APPL mother-your
 ‘What did you buy your mother?’
- b. **Siapa**₁ yang kamu (***mem**-)beli-kan ___₁ bunga?
 who that you (***ACT**-)buy-APPL flower
 ‘Who did you buy a flower/flowers?’ [Sato 2012:43, ex. (18b,c)]

If the extraction is long-distance, *meN*- must disappear on every verb that is crossed by it. This is illustrated for long object extraction in (6). For long subject extraction, *meN*- does not need to delete in the lowest clause (in line with (4c)) but in all higher ones, as in (7).

- (6) *Long object extraction*
Siapa-kah₁ yang Ali (***meng**-)anggap [Minah \emptyset -suka ___₁]?
 who-Q that Ali (***ACT**-)believe Minah like
 ‘Who does Ali believe Minah likes?’ [Soh 1998:298, ex. (11b,c)]
- (7) *Long subject extraction*
Siapa-kah₁ yang Ali (***meng**-)anggap [___₁ **men**-yukai Karim]?
 who-Q that Ali (***ACT**-)believe ACT-like Karim
 ‘Who does Ali believe likes Karim?’ [Soh 1998:297–298, ex. (11a,d)]

This pattern is not limited to wh-movement, but also holds for other \bar{A} -movements, such as relativization (Cole and Hermon 1998:233, Sato 2012:34) and focus movement (Cole and Hermon 1998: 233).

Significantly, \bar{A} -movement of elements that are not DPs does not have this effect (Cole and Hermon 1998, Soh 1998, Fortin 2006, 2007, Sato 2012). Movement of PPs or adverbs does not trigger

meN-deletion, even if the element originates within the vP, as shown in (8). If a non-DP undergoes long movement, no *meN*-deletion takes place in either clause, as illustrated in (9).

(8) *Non-DP movement*

- a. [**Kepada siapa-kah**]₁ Minah **mem**-beri kucing kesayangannya ___₁?
to who-Q Minah ACT-give cat beloved.her
‘To who did Minah give her beloved cat?’ [Soh 1998:313, ex. (32b)]
- b. **Kenapa**₁ Mary **mem**-beli buku itu ___₁
why Mary ACT-bought book that
‘Why did Mary buy that book?’ [Cole and Hermon 1998:231, ex. (26a)]

(9) *Long non-DP movement*

- a. [CP [**Kepada siapa**]₁ kamu **meng**-harapkan [CP Ali akan **mem**-beri
to who you ACT-hope Ali FUT ACT-give
mobil+nay ___₁]]?
car+3SG
‘To who do you hope Ali will give his car?’
- b. [CP **Mengapa**₁ kamu **meng**-harapkan [CP Ali akan **mem**-beli mobil ___₁]]?
why you ACT-hope Ali FUT ACT-buy car
‘Why do you hope Ali will buy a car?’ [Fortin 2007:51–52, ex. (73), (78)]

In a nutshell, then, every DP that \bar{A} -moves across a transitive verb triggers deletion of *meN*-.

2.2. vP-phase accounts

Aldridge (2008b), Cole et al. (2008), Sato (2012), Georgi (2014), and Jeoung (2018) all interpret this pattern as evidence for vP phases. While their respective accounts differ in significant ways, the guiding analytical intuition is that an object DP must move to [Spec,vP] on its way to [Spec,CP], and this movement to [Spec,vP] bleeds *meN*-, resulting in the derivation in (10). Where these accounts differ is how this bleeding effect is implemented. Aldridge (2008b) and Sato (2012) propose that v bears a designated feature that attracts an object DP to its edge (EPP for Aldridge 2008b; [+D] for Sato 2012), which then prevents realization of *meN*-. Georgi (2014:151–156) proposes that *meN*- is bled by an impoverishment rule that is triggered if [Spec,vP] contains a DP with a valued case feature.

$$(10) \quad [_{CP} DP_1 C \dots [_{vP} t_1 [_{vP} DP v [_{vP} V t_1]]]]$$

Accounts that attribute *meN*-deletion to vP phasehood successfully derive the basic empirical pattern but face a number of significant obstacles beyond that basic pattern. First, the fact that extraction of non-DPs does not bleed *meN*- is somewhat puzzling under these accounts. Clearly, if vP is a phase, then PPs must also move through [Spec,vP]. But why does this movement step not lead to *meN*-deletion in the same way as DP movement does? If PPs must check the same feature that DPs check in order to move to [Spec,vP], then they too should block *meN*-, contrary to fact.

On the other hand, if PPs can reach the vP edge without checking this feature, then it is not clear why DPs cannot do so as well. The underlying problem here is that, empirically, *meN*-deletion is sensitive to the type of the moving element. But a vP-phase account requires *all* elements to move successive-cyclically through [Spec,vP]. Additional stipulations are therefore necessary to ensure that such movement affects the voice prefix only if the moving element is a DP.³ We will show that a DP-intervention account allows for a more direct link between *meN*-deletion and successive cyclicity, which avoids this issue altogether.

Second, a similar but not identical blocking effect is observed with the passive-voice prefix *di-* (Soh 1998). In passive clauses, the internal argument appears preverbally, and the agent argument can be expressed either as a PP (using the preposition *oleh* ‘by’) or as a plain DP (see Guilfoyle et al. 1992, Arka and Manning 1998, Legate 2014), as shown in (11).

(11) *Passive voice*

- a. Patung itu **di**-beli oleh Minah.
doll the PASS-buy by Minah
‘The doll is bought by Minah.’
- b. Patung itu **di**-beli Minah.
doll the PASS-buy Minah
‘The doll is bought by Minah.’

[Soh 1998:303–304, ex. (34a,b)]

Guilfoyle et al. (1992) argue that *Minah* in (11b) is a DP that is base-generated in the standard position of external arguments, i.e. [Spec,vP] in our terminology. The internal argument *patung itu* ‘the doll’ then undergoes movement to a position above *Minah*. For the sake of concreteness, we also follow Soh (1998:303n8) in assuming that post-verbal position of the external argument *Minah* is the result of extraposition.

Importantly, \bar{A} -extraction of the agent is impossible if it is a DP, regardless of whether the passive prefix *di-* is retained or deleted:⁴

³ The only vP-phase accounts that directly address these questions that we are aware of are Cole et al. (2008) and Georgi (2014). Cole et al. (2008) propose that *v* acquires the Case features of all DPs in its specifier(s) (see Erlewine 2016 for related suggestions). Movement of an object to [Spec,vP] leads to an [ACC] specification in addition to the [NOM] specification contributed by the external argument, which gives rise to a feature conflict, which *meN-* does not tolerate, leading to ungrammaticality. Extending this account to long-distance subject extraction such as (7) seems to require additional assumptions because both specifiers of the higher *v* bear [NOM], which does not obviously create a feature conflict.

For Georgi (2014), the fact that only DPs delete *meN-* follows from the formulation of the impoverishment rule. The subject/object asymmetry is captured because the impoverishment applies only if the DP has a valued case feature. Subjects are taken to receive case in [Spec,TP], so that the copy in [Spec,vP] is caseless and hence does not trigger the rule. This analysis appears at odds with the standard view that feature valuation takes place in syntax and impoverishment applies postsyntactically. On this architecture, all features are valued by the time impoverishment applies, and as a result impoverishment cannot distinguish between DPs with valued and unvalued case features. The subject–nonsubject distinction would then be lost.

⁴ As Hooi Ling Soh (p.c.) informs us, the version of (12) without *di-* is grammatical on the interpretation ‘Who did that doll buy?’—that is, as an active clause with extraction of the theme argument and deletion of *meN-*. This is unsurprising, of course.

- (12) *Agent-DP extraction impossible in passives*
 ***Siapa-kah** yang patung itu (**di-**)beli?
 who-Q that doll the (PASS-)buy
Intended: ‘Who was the doll bought (by)?’ [Soh 1998:304, ex. (35); Hooi Ling Soh, p.c.]

If the moving agent is a PP, on the other hand, then \bar{A} -extraction is permitted and the passive-voice prefix *di-* is retained:

- (13) *Agent-PP extraction possible in passives*
 [**Oleh siapa-kah**] patung itu **di-**beli?
 by who-Q doll the PASS-bought
 ‘By whom was the doll bought?’ [Soh 1998:304, ex. (36)]

These extraction facts are clearly similar to what we saw for *meN-*: Extraction of a lower DP is prohibited over an overt voice prefix, while extraction of a PP is not restricted in this way. But while this restriction may be circumvented by deletion of *meN-*, deletion of *di-* does not restore grammaticality. These facts constitute a challenge for an account in terms of vP phases. (14) shows the structure of (12) on such an account. \bar{A} -extraction of the external argument *siapa-kah* ‘who’ is ungrammatical.

- (14) * $[_{CP}$ Siapa-kah₁ yang patung itu₂ [_{vP} t₁ v [_{vP} beli t₂]]]
- who-Q that doll the buy
-

The puzzle for a vP-phase account is that *siapa-kah* is the external argument, generated in [Spec,vP] (Guilfoyle et al. 1992) and therefore at the vP-phase edge. The fact that it cannot undergo \bar{A} -movement therefore cannot be attributed to vP phasality. More generally, vP phases fail to distinguish between the external argument of an active clause—which may undergo \bar{A} -movement (4c)—and the external argument of a passive clause—which may not undergo such \bar{A} -movement (12). As a result, a vP-phase account must attribute the restriction in (12)/(14) to something other than vP phases. But this is undesirable for two reasons. First, this restriction is clearly very similar to the ban on \bar{A} -movement of DPs over *meN-* (Soh 1998), which such an account attributes to vP phases. A generalization would therefore be missed. Second, whatever constraint derives (14) might then potentially also be used to derive the original *meN-*-deletion facts, with no need for vP phases. This is the line of analysis we pursue in the next section.

2.3. DP-intervention analysis

Our alternative analysis is inspired by these previous accounts, and it maintains the core intuition that *meN-*-deletion is triggered by movement of a DP a higher position, but we analyze this movement as required not because of vP phases but because of minimality/intervention by a higher DP.

First, we assume that Indonesian lacks obligatory movement of subjects to [Spec,TP]. Evidence comes from the observation that unaccusative verbs allow their sole argument to appear in a postverbal position (Soh and Nomoto 2011:88–89, Jeoung 2018:82), as illustrated in (15).

- (15) Kalau tidak turun **harga minyak**, kita akan bankrap.
 if not fall price oil we will bankrupt
 ‘If the oil price doesn’t fall, we’ll go bankrupt.’ [Soh and Nomoto 2011:89, ex. (28b)]

We conclude from (15) that Indonesian T does not require its specifier position to be filled and hence that verbal arguments remain inside the vP.

Second, we locate the syntactic locus of *meN*-deletion in v, following the standard view. Deletion of *meN*- is closely tied to voice: not only is the *meN*- that undergoes the deletion often analyzed as an active-voice marker (e.g., Aldridge 2008b, Sato 2012, Georgi 2014, Legate 2014), the basic strategy of deleting a voice head to enable \bar{A} -movement of a lower DP is not available for all voice heads, as we already saw. For example, (12) shows that the passive-voice prefix *di-* also blocks \bar{A} -movement of DPs but dropping the voice prefix does not have a rescuing effect here. The sensitivity of the effects and its rescue strategy to values of voice thus indicates that it is syntactically located in Voice or v (we will use the label “v” and “vP” in what follows). We propose that v in Indonesian has at least the three “flavors” in (16). The v head *meN*- does not contain movement-inducing features and so it does not change the structural relationship between vP-internal DPs. The v head *di-* contains a feature [*uD*] that attracts the closest DP in v’s c-command domain to v’s specifier. Finally, the null v head contains a [*u δ*] feature. Following Miyagawa (2017), we use the cover term “[*u δ*]-feature” to refer to movement-inducing information-structural features. This feature is optionally instantiated on constituents, and [*u δ*] attracts the closest constituent that bears [δ].

- (16) a. *meN*-: does not contain movement-inducing features
 b. *di*-: contains a movement-inducing [*uD*] feature
 c. \emptyset -: contains a movement-inducing [*u δ*] feature

Because the v head *meN*- does not induce movement, it does affect the structural relationship between an internal and an external argument—the external argument is the highest DP within the vP. By contrast, both the *di*- v head and the \emptyset - v head induce movement of a VP-internal element over the external argument. The *di*- head results in A-movement of the closest DP to an outer [Spec,vP]; \emptyset - attracts the closest element with an [δ] feature to an outer [Spec,vP]. For our purposes, the outcome is the same: the external argument is no longer the closest DP to C.⁵

Against the background of these assumptions (DPs do not move out of vP and the choice of the voice head determines which DP is highest within the vP), we propose a minimality/intervention account of the Indonesian extraction restriction. We adopt the proposal in Erlewine (2018), Coon

⁵ Our reason for treating movement triggered by *di-* as A-movement and movement triggered by the null v as \bar{A} -movement stems from weak crossover. On the analysis we develop here, both (ia) and (ib) involve leapfrogging over the external argument. In the passive sentence (ib), this leapfrogging may feed binding of a pronoun inside the external argument; in the active sentence (ia), it may not. Following Van Urk (2015), we ground this asymmetry in the nature of the feature that underlies the movement: [*uD*] results in A-movement, which is not subject to weak crossover, whereas [*u δ*] results in \bar{A} -movement, which is:

et al. (2021), and Branan and Erlewine (2021) that an \bar{A} -probe may be specified not just for an \bar{A} -feature but also for a categorical feature (also see Baier 2018). C in Indonesian thus has the makeup in (17) (to be extended below). (17) contains a complex probe that searches for both $[u\delta]$ and $[uD]$. As before $[u\delta]$ is an umbrella feature that triggers \bar{A} -movement, including wh-movement, focus fronting, and relativization, all of which pattern alike with respect to *meN*-deletion.

(17) C: $[u\delta+uD]$

Erlewine (2018), Coon and Keine (2021), Coon et al. (2021), and Branan and Erlewine (2021) argue that complex probes of this type cannot attract a fully-matching goal over a partially matching one. This restriction is stated in (18) and schematized in (19). In (19), the probe $[uA+uB]$ comprises the two segments $[uA]$ and $[uB]$. YP contains only a matching feature $[A]$, and ZP contains a full $[A+B]$ match. It is then not possible for the probe to attract ZP over YP.

(18) A complex probe cannot attract a fully-matching element across a partially-matching element.

(19) $*[_{XP} \text{---} X_{[uA+uB]} [\dots YP_{[A]} \dots ZP_{[A+B]} \dots]]$

Erlewine (2018:686–687) and Branan and Erlewine (2021) implement (18) at the level of the Agree operation: a complex probe that encounters a partially-matching element stops probing. It is therefore the Agree step in (19) that is illicit (and movement is thus impossible to begin with). Coon et al. (2021) derive this result from Coon and Keine’s (2021) feature-gluttony system, according to which the complex probe $[uA+uB]$ enter into Agree with both YP and ZP, which rules out to the movement step in (19) (for details, see Coon and Keine 2021 and Coon et al. 2021). Both ways of deriving (19) are compatible with what is to come. We will therefore focus on the effects of (18), rather than on the specific way (18) is derived from deeper principles.

Let us first consider active-voice sentences with the *v* head *meN*- in (16a). This head bears no movement-inducing features, and so the external argument will be the closest DP to C. If the external argument bears a $[\delta]$ feature, it matches both $[uD]$ and $[u\delta]$ on C and is hence attracted to $[\text{Spec,CP}]$.

(20) *Local subject extraction with meN-*

$[_{CP} DP_{[\delta]} C_{[u\delta+uD]} \dots [_{VP} t \underline{v} (\rightarrow meN-) [_{VP} V DP]]]$

(i) a. *Siapa-kah_i yang ____i emak-nya_i sayang ____i?
 who-Q that mother-his love
 ‘Who_i does his_i mother love?’

b. Siapa-kah_i yang ____i di-sayangi emak-nya_i ____i?
 who-Q that PASS-love mother-his
 ‘Who_i is loved by his_i mother?’

[Soh 1998:300, ex. (21b,c)]

By contrast, if it is a lower DP that bears $[\delta]$, the external argument intervenes because it constitutes a partial match to the probe on C. The condition in (18) then prevents \bar{A} -movement of the $[\delta]$ -bearing lower DP to [Spec,CP].

(21) *No object extraction with meN- due to (18)*

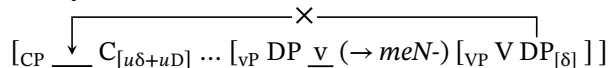

As a result, if the v head *meN-* is used, the structurally closest DP to C in a transitive clause is invariably the external argument. \bar{A} -extraction can therefore target only this DP, ruling out \bar{A} -extraction of lower DPs when the voice prefix *meN-* is present.

Let us now turn to the v head \emptyset - (16c). This v head bears a $[u\delta]$ feature that attracts the closest element bearing $[\delta]$ to an outer [Spec,vP], leading to leapfrogging over the external argument. This movement puts the leapfrogged DP into a position that is closer to C than the external argument, which enables \bar{A} -extraction of the leapfrogged DP.

(22) *Local object extraction with \emptyset -*

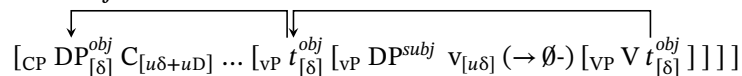

Because leapfrogging over the external argument is required for \bar{A} -extraction of any DP other than the local subject, it follows that such extraction is possible if the v head \emptyset - is chosen but not if the v head *meN-* is chosen because only \emptyset - carries the prerequisite feature for leapfrogging. The effect is that the prefix *meN-* has to be absent if a DP other than the local subject is fronted. This derives the key empirical generalization underlying *meN-*-deletion.⁶

Long-distance DP extraction proceeds analogously. In order for the embedded argument to be attractable by matrix C, it must first leapfrog around the external argument of the matrix clause, requiring matrix T to bear $[u\delta]$ and hence bleeding *meN-* in the matrix clause.

We now briefly turn to sentences with the passive-voice prefix *di-*. In these sentences, the external argument may be realized as a *by*-phrase or as a DP (see (11)), but the internal argument undergoes obligatory movement to a position above the external argument. We implemented this movement by equipping the passive v head *di-* with a $[uD]$ feature (16b). What is crucial for our purposes is that the presence of this feature leads to obligatory leapfrogging: the internal argument is moved to a position that is closer to C than the external argument. This prevents C from attracting an external-argument DP in a passive (see (12)), as shown in (23).

(23) *No extraction of external-argument DP with di- due to (18)*

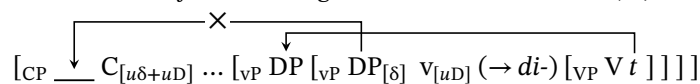

⁶ One question that arises is whether it is possible to use the null v head if there is no $[\delta]$ -bearing DP. On the one hand, if $[u\delta]$ on this v does not need to find a goal (following Preminger 2014), then the structure is expected to be grammatical without any \bar{A} -movement. On the other hand, if $[u\delta]$ needs to be licensed through Agree with $[\delta]$, then we expect the structure to be ungrammatical. Interestingly, as noted above, this is where varieties of Indonesian/Malay diverge. For some speakers, *meN-* is in free alternation with the null voice head in the absence of extraction, while for other speakers *meN-* is obligatory. It is therefore tempting to try to understand this variation along the lines just mentioned: for the first group of speakers, $[u\delta]$ on v does not need to be checked whereas for the second group of speakers it needs to be.

This analysis also explains why deletion of *di-* does not enable \bar{A} -extraction of the external argument in the same way that deletion of *meN-* enables \bar{A} -extraction of an internal argument. The null voice prefix $\emptyset-$ in (16c) likewise leads to leapfrogging of the internal argument over the external argument. Extraction of the external argument is therefore blocked in the same way it is in (23).

Recall from section 2.2 that the movement restriction in (23) does not follow from vP phases, because the lower DP, whose movement is blocked, is located at the vP edge. (23) thus provides an argument that a minimality-based constraint is necessary for a comprehensive account of Indonesian. As we have just shown, such a minimality-based constraint also managed to handle the original *meN*-deletion facts, making superfluous additional appeal to vP phases.

A second argument for a minimality account over a vP-phase account comes from extraction of non-DPs. Recall from (8) that \bar{A} -extraction of PPs and adverbs does not lead to obligatory *meN*-deletion even if the element clearly originates within the vP. A relevant example is repeated in (24). Here, local extraction of a PP object does not delete *meN-*.

- (24) [**Kepada siapa-kah**]_i Minah **mem-**beri kucing kesayangannya ____i?
to who-Q Minah ACT- give cat beloved.her
‘To who did Minah give her beloved cat?’ [Soh 1998:313, ex. (32b)]

Let us take (24) at face value: if obligatory *meN*-deletion is a reflex of successive-cyclic movement through vP, then the fact that it does not apply in (24) suggests that the movement in (24) does *not* proceed through [Spec,vP]. Such an analysis is of course impossible if vP constitutes a phase, but it becomes available on the intervention/minimality account we propose here. Broadly speaking, our proposal is that for C in Indonesian, minimality is assessed on a categorial level: if C attracts a DP, it must be the closest DP; if C attracts a PP, it must be the closest PP, etc. Indeed, there is evidence that \bar{A} -movement of DPs differs syntactically from \bar{A} -movement of PPs and adverbs in Indonesian.⁷ While \bar{A} -fronted wh-DPs can or must precede the complementizer *yang* depending on the register (Fortin 2007:50, Cole and Hermon 1998:224n5), fronted PPs and adverbs are incompatible with *yang* (Fortin 2007:51–53, Jeoung 2018:31). This contrast is illustrated in (25).

- (25) a. **Mengapa** (*yang) kamu sedang menangis?
why (*that) you PROG cry
‘Why are you crying?’
b. **Dengan siapa** (*yang) Ali berdansa?
with who (*that) Ali dance
‘With who did Ali dance?’ [Fortin 2007:51–52, ex. (76a), (80b)]

We therefore propose that there are several flavors of C in Indonesian, which differ in their featural content and their phonological form. \bar{A} -fronting of PPs and adverbs is triggered by different flavors of C, which bear the featural makeup in (26b,c).

- (26) a. C_{yang} : [u δ +uD] (= (17))
b. C_{\emptyset} : [u δ +uP]

⁷ Our thanks to an anonymous reviewers for pointing this out.

c. C_{\emptyset} : [$u\delta+uAdv$]

(26b) and (26c) attract focused PPs and adverbs, respectively. Importantly, nonfocused DPs do *not* constitute a partial match to either (26b) or (26c). Such DPs therefore do not cause an intervention effect, in line with (18) and (19). Because external arguments are always DPs, it follows that PPs and adverbs do not need to leapfrog over the external argument in order to be attractable by C. PPs and adverbs may thus \bar{A} -move to [Spec,CP] in one-fell-swoop, as illustrated for PPs in (27). Because no leapfrogging is required for \bar{A} -movement of the PP, v may be *meN*-. This explains why *meN*-deletion is required only for DP movement but not for movement of PPs or adverbs.

(27) *PP-extraction possible without leapfrogging*

$$[_{CP} \underline{\quad} C_{[u\delta+uP]} [\dots [_{TP} DP \underline{v} (\rightarrow meN-) [\dots PP_{[\delta]}]]]]$$

The DP/non-DP asymmetry is thus derived from category-based intervention (18) and the fact that external arguments are DPs. This line of explanation is not available on a vP-phase account. On such an account, *all* extraction must pass through [Spec,vP], and it is therefore necessary to encode in some other way that only DPs in [Spec,vP] have this effect but PPs and adverbs do not. Dispensing with vP phases hence paves the way for a tighter connection between *meN*-deletion and successive cyclicity through vP: in an active clause, *meN*-deletion is obligatory *if and only if* movement passes through [Spec,vP].

A third argument in favor of a minimality account over a vP-phase account comes from unaccusatives and passives. As discussed by Sato (2012), Georgi (2014), and Jeoung (2018), it is possible for *meN*- to mark intransitive verbs, including unaccusative verbs. An example is provided in (28). Jeoung (2018:81) provides several examples of intransitive verbs that may bear *meN*-, including crosslinguistically unaccusative verbs like *me-letus* ‘burst’, *men-cair* ‘melt’, *men-didih* ‘boil’, and *men-ikah* ‘be married’.⁸

(28) Harga elektrik tiba-tiba {turun/**men**-urun}.
 price electricity suddenly fall ACT- fall
 ‘The price of electricity suddenly fell.’

[Jeoung 2018:87, ex. (52)]

On a vP-phase account such as Sato’s (2012:46), (28) entails that the internal argument of (*t*)*urun* ‘fall’ must be able to move out of the vP or to [Spec,vP] (depending on whether *harga elektrik* ‘the price of electricity’ is taken to occupy [Spec,vP] or [Spec,TP] in (28)) without incurring *meN*-deletion.

⁸ Some comments are in order. First, Soh and Nomoto (2011) propose that in Indonesian all intransitive verbs that bear *meN*- are unergative. See Sato (2012:44–46) for arguments against this view. Second, Sato (2012) proposes that *meN*- that appears on unaccusative verbs is distinct from *meN*- on transitive verbs because the former contributes a progressive meaning component absent in the latter. But doing so not only leaves it unexplained why the two have the same form (Soh and Nomoto 2011:88, Georgi 2014:155n100), there also seems to be little empirical motivation for such a split. Soh and Nomoto (2009) provide relevant evidence showing that *meN*- is impossible in sentences that denote states (also see Soh and Nomoto 2011). Importantly, this restriction holds for both transitive and intransitive verbs, and Soh and Nomoto (2009, 2011) conclude that *meN*- should be treated as the same item with both types of verbs. Moreover, Jeoung (2018:87–88) shows that even with unaccusative verbs, the progressive interpretation seems to be a preference rather than a semantic requirement. We therefore follow Soh and Nomoto (2009, 2011) and Georgi (2014) in treating *meN*- on intransitive verbs as the same voice marker as on transitive verbs.

To achieve this, Sato (2012) adopts Chomsky’s (2000, 2001) assumption that the defective *v* that occurs in unaccusatives and passives and does not introduce an external argument does not behave as a phase. As such, extraction out of *vP* does not need to pass through the *vP* edge and *meN*-deletion therefore does not apply. Because unaccusative *v* appears not only with unaccusative verbs but also in passive clauses that lack external arguments (Chomsky 2001:12), this analysis makes the immediate prediction that such passives should pattern analogously. But this is not the case, as shown in (29) and (30). Both clauses involve a passivized ditransitive structure without an external argument. In (29), the higher object is \bar{A} -fronted, and the sentence is grammatical. In (30), the lower object is \bar{A} -fronted and the result is ungrammatical (see also Cole et al. 2008:1510–1511 for an analogous contrast).

(29) **Siapa**₁ yang di-beli-kan ___₁ bunga?
 who that PASS-buy-APPL flower
 ‘Who was bought a flower/flowers?’

(30) ***Apa**₁ yang ibu-mu di-beli-kan ___₁?
 what that mother-your PASS-buy-APPL
 ‘What was your mother bought?’

[Mitcho Erlewine, p.c.]

If the defective *vP* that occurs in unaccusatives and passives is not phasal, as suggested by (28), then there is no phase-based reason why the extraction in (30) is ungrammatical (as no phase boundary is crossed). (30) would therefore require an account that is unrelated to that of *meN*-deletion, despite their similarities. By contrast, a minimality account derives the pattern in (28)–(30) without further ado. The reason that \bar{A} -movement of the direct object is blocked in (30) is due to intervention by the indirect object, as shown in (31).

(31)
$$\begin{array}{c} \downarrow \qquad \qquad \qquad \downarrow \qquad \qquad \qquad \times \qquad \qquad \qquad \downarrow \\ [_{CP} \quad \underline{\quad} \quad C_{[u\delta+uD]} \quad \dots \quad [_{vP} \quad ibu\text{-}mu_1 \quad v_{[uD]} \quad (\rightarrow di\text{-}) \quad [_{AppIP} \quad t_1 \quad Appl \quad [_{VP} \quad beli \quad apa \quad]]]]] \\ \text{mother-your} \qquad \qquad \qquad \text{buy} \quad \text{what} \end{array}$$

In (29), it is the indirect object that is \bar{A} -moved. Because the indirect object is the highest DP within the *vP*, this extraction is correctly permitted by our minimality account. Finally, we account for the presence of *meN*- in (28) because no leapfrogging needs to take place in this structure, given the absence of an intervening DP.

To summarize, we have shown that the extraction restriction with *meN*- and *di*- arises in precisely those cases where one DP must move over another in order to be closest to *C*. This pattern receives a principled explanation on a minimality/intervention account. An account in terms of domain locality, like *vP* phases, provides a considerably less close match to the empirical pattern, requiring additional stipulations to derive the observations that (i) the restriction applies only to extraction of DPs, (ii) external arguments of passives are restricted in the same way, and (iii) the divergent behavior of unaccusative and passive configurations.

3. Dinka *ké*-morphology

One particularly strong and well-developed argument for successive cyclicity through [Spec,vP] and vP phasehood (and thus for clause-internal phasality) is presented by Van Urk (2015, 2018) and Van Urk and Richards (2015) for the Nilotic language Dinka. The argument is two-pronged. First, extraction has an empty-position effect within the vP; second, such extraction leads to the appearance of the special marker *ké* in the vP region. In this section, we argue for a reanalysis of these patterns in terms of DP intervention and leapfrogging rather than vP phases, in line with the general conclusions we reached for Indonesian. There is also an important difference between our analysis of Indonesian and Dinka: while we located the landing site of the leapfrogging step in an outer [Spec,vP] in Indonesian, we locate it in an outer [Spec,TP] in Dinka. We suggest that this difference correlates with the location of the subject in the two languages, as predicted by an DP-intervention account.

3.1. Empirical evidence

3.1.1. V2 effects

As illustrated in (32), Dinka is a V2 language, with exactly one constituent preceding a verbal element in the second position of the clause.

- (32) a. Àyén à-**càm** cuḷin nẹ pǎal.
Ayen 3P-eat food P knife
'Ayen is eating food with a knife.'
- b. Cuḷin à-**céem** Áyèn nẹ pǎal.
food 3P-eat.OV Ayen.GEN P knife
'Food, Ayen is eating with the knife.'
- c. Pǎal à-**céemè** Áyèn cuḷin.
knife 3P-eat.OBLV Ayen.GEN food
'With a knife, Ayen is eating food.'
- [Van Urk 2018:942, ex. (6a–c)]

Turning to the Dinka vP, Van Urk (2015, 2018) and Van Urk and Richards (2015) argue that here too we find a V2 property such that exactly one constituent precedes the verb in the vP. For example, in a transitive clause, the object must occur in a preverbal position, as shown in (33).

- (33) a. Yéen cé miir tḷḷ.
I PFV giraffe see
'I saw a giraffe.'
- b. *Yéen cé ____ tḷḷ miir.
I PFV see giraffe
'I saw a giraffe.'
- [Van Urk and Richards 2015:122, ex. (14a,b)]

If the vP is ditransitive, one of the two objects must occupy the preverbal position, as (34a–b) illustrates. It is not possible for both objects to occur postverbally (34c–d), nor is it possible for both objects to occur preverbally (34e–f).

- (34) a. $\forall\text{ɛn}$ $\text{c}\acute{\text{e}}$ Ayén $\text{y}\acute{\text{i}}\text{n}$ $\text{k}\acute{\text{i}}\text{t}\acute{\text{a}}\text{p}$.
 I PFV Ayen give book
 ‘I gave Ayen a book.’
- b. $\forall\text{ɛn}$ $\text{c}\acute{\text{e}}$ kítáp $\text{y}\acute{\text{i}}\text{n}$ Ayén.
 I PFV book give Ayen
 ‘I gave a book to Ayen.’ [Van Urk and Richards 2015:122, ex. (15a,b)]
- c. * $\forall\text{ɛn}$ $\text{c}\acute{\text{e}}$ ____ $\text{y}\acute{\text{i}}\text{n}$ $\text{k}\acute{\text{i}}\text{t}\acute{\text{a}}\text{p}$ Ayén.
 I PFV give book Ayen
- d. * $\forall\text{ɛn}$ $\text{c}\acute{\text{e}}$ ____ $\text{y}\acute{\text{i}}\text{n}$ Ayén $\text{k}\acute{\text{i}}\text{t}\acute{\text{a}}\text{p}$.
 I PFV give Ayen book [Van Urk and Richards 2015:122–123, ex. (16a,b)]
- e. * $\forall\text{ɛn}$ $\text{c}\acute{\text{e}}$ kítáp Ayén $\text{y}\acute{\text{i}}\text{n}$.
 I PFV book Ayen give
- f. * $\forall\text{ɛn}$ $\text{c}\acute{\text{e}}$ Ayén kítáp $\text{y}\acute{\text{i}}\text{n}$.
 I PFV Ayen book give [Van Urk and Richards 2015:122n11, ex. (i.a,b)]

If there is no object, the preverbal position remains empty. Adjuncts cannot occupy this position and must appear postverbally, as in (35).

- (35) a. $\text{W}\acute{\text{o}}\text{k}$ $\text{c}\acute{\text{e}}$ ____ $\text{k}\acute{\text{e}}\text{t}$ $\text{d}\acute{\text{o}}\text{m}$ - $\acute{\text{i}}\text{c}$.
 we PFV sing garden-in
 ‘We sang in the garden.’
- b. * $\text{W}\acute{\text{o}}\text{k}$ $\text{c}\acute{\text{e}}$ dòm-íc $\text{k}\acute{\text{e}}\text{t}$.
 we PFV garden-in sing
 ‘We sang in the garden.’ [Van Urk and Richards 2015:123, ex. (17a,b)]

Van Urk (2015, 2018) and Van Urk and Richards (2015) analyze this preverbal position as [Spec,vP], though we will diverge from this view in our own analysis.

If there is a movement dependency, every [Spec,CP] and preverbal position along the movement path must be empty. This is shown for [Spec,CP] in (36) and for the preverbal position in (37). As (37a) shows, it is possible for movement to target the preverbal object in a ditransitive configuration (whether it is a direct or indirect object). By contrast, (37b) shows that it is not possible to move the postverbal DP.

- (36) a. $\text{Y}\acute{\text{e}}\text{n}\acute{\text{a}}$ $\text{c}\acute{\text{y}}\text{k}\text{k}\grave{\text{u}}$ $\text{l}\acute{\text{u}}\acute{\text{e}}\text{l}$, [_{CP} ____ $\text{c}\acute{\text{e}}$ $\text{k}\acute{\text{i}}\text{t}\acute{\text{a}}\text{p}$ $\text{y}\acute{\text{o}}\text{c}$]?
 who PFV.1PL say PFV book buy.TR
 ‘Who did we say bought a book?’

- b. *Yeṅà cǔkkù luéel, [_{CP} kítáp (à-)cǐ ɣòɔc]?
 who PFV.1PL say book (3SG-)PFV.NSV buy.TR
 ‘Who did we say bought a book?’ [Van Urk and Richards 2015:125, ex. (21a,b)]
- (37) a. Yeṅà cǐ môc _____ yiḡn kítáp?
 who PFV.NSV man.GEN give book
 ‘Who did the man give the book to?’
- b. *Yeṅà cǐ môc kítáp yiḡn?
 who PFV.NSV man.GEN book give
 ‘Who did the man give the book to?’ [Van Urk and Richards 2015:125, ex. (20a,b)]

Van Urk (2015, 2018) and Van Urk and Richards (2015) analyze both effects in terms of phases. (36) follows from CP phases. And based on the analysis of the preverbal position as [Spec,vP], (37) is attributed to vP phases: only an object that has shifted to [Spec,vP] is accessible for further movement to [Spec,CP]. One-fell-swoop extraction as would be necessary in (37b) is therefore ruled out.⁹

3.1.2. *Ké-stranding*

As investigated in detail by Van Urk (2015), Van Urk and Richards (2015), and in particular Van Urk (2018), in addition to this empty-position effect, \bar{A} -extraction out of vP in Dinka yields special morphology, as we now discuss. Whenever a plural element is moved out of vP in Dinka except for local subjects, the element *ké* (or *kêek*) must appear next to every verb that is crossed by the movement. This element is homophonous with (and, depending on the analysis, identical to) the 3rd person plural pronoun. The appearance of *ké* is illustrated in (38), where \bar{A} -movement of *yeyiṅà* ‘who.PL’ and *kêek* ‘them’ requires a preverbal *ké*, which is impossible in the absence of such movement.

- (38) *Object \bar{A} -movement triggers ké*
- a. **Yeyiṅà** cǐ Ból **ké** t̩ṅ?
 who.PL PFV.NSV Bol.GEN PL see
 ‘Who all did Bol see?’ [Van Urk and Richards 2015:127, ex. (23b)]
- b. **Kêek** áa-cǐ Áyèn **ké** t̩ṅ.
 them 3PL-PFV.OV Ayen.GEN PL see.NF
 ‘Them, Ayen has seen.’ [Van Urk 2018:947, ex. (19c)]

Van Urk (2015, 2018) shows that *ké* is associated with movement and not a resumptive pronoun in the standard sense. First, resumptive pronouns in Dinka are normally limited to PP positions (Van Urk 2015:151–154). Second, displacement with *ké* still shows island sensitivity and allows for reconstruction of the displaced element (Van Urk 2018:951–952). Third, genuine resumptive pronouns are not limited to plural DPs (like *ké* is) but appear with singular DPs as well. We therefore follow Van Urk (2015, 2018) in treating *ké* as the reflex of a movement dependency.

⁹ Note that this analysis requires that *yeyà* ‘who’ in (37b) cannot pass through a second [Spec,vP] on its way to [Spec,CP], a restriction that the theory in Van Urk (2015) and Van Urk and Richards (2015) derives.

The marker *ké* is restricted to the clause-medial region—it cannot appear in C or [Spec,CP]. Furthermore, *ké* is φ -sensitive in that it only appears if the moving element is plural, as (39) demonstrates, where the corresponding 3SG element *yé(en)* may not occur and *ké* would also be ungrammatical.

- (39) *Singular DPs do not trigger a corresponding SG marker*
 Yè **ɲà** [CP *cíi* Ból [VP (***yé(en)**) *t̩iŋ*]]?
 be.3SG who PFV.OV Bol.GEN (*3SG) see.NF
 ‘Who has Bol seen?’ [Van Urk 2018:940–941, ex. (5a,b)]

1st and 2nd person plural DPs likewise trigger *ké*:

- (40) *\bar{A} -movement of 1st/2nd plural DP triggers *ké**
Wòk/Wèek *cíi* Áyèn **ké** *t̩iŋ*.
 1PL/2PL PFV.OV Ayen.GEN 3PL see.NF
 ‘Us/You all, Ayen has seen.’ [Van Urk 2015:225, ex. (62a,b)]

The appearance of *ké* exhibits the hallmark property of successive cyclicity: it appears in every clause that is crossed by movement, as (41) illustrates.

- (41) **ké* appears in every clause crossed by movement*
Yeyíŋà *yé* **ké** *tàak*, [CP *cíi* Ból **ké** *t̩iŋ*]?
 who.PL HAB.2SG PL think PFV.NSV Bol.GEN PL see
 ‘Who all do you think Bol saw?’ [Van Urk and Richards 2015:128, ex. (25b)]

There is furthermore a subject-object asymmetry in that \bar{A} -extraction of a local subject does not lead to *ké*, as (42) shows. But in crossclausal \bar{A} -extraction of a plural subject, *ké* appears in higher clauses, as in (43).

- (42) *\bar{A} -movement of local subject does not trigger *ké**
Ròòòr *áa-cé* (***ké**) *y̩in t̩iŋ*.
 men 3P-PFV (*PL) you see.NF
 ‘The men have seen you.’ [Van Urk 2018:950, ex. (25a)]

- (43) *\bar{A} -movement of nonlocal subject triggers *ké* in higher clauses*
Ròòòr *áa-yùukù* **ké** *tàak* [CP *cé* (***ké**) *y̩in t̩iŋ*].
 men 3PL-be.1PL PL think.NF PFV (*PL) you see.NF
 ‘The men, we think have seen you.’ [Van Urk 2018:950, ex. (26a)]

Finally, certain adjuncts that contain a plural DP also trigger *ké*. This is shown in (44a,b) for movement of *thèek-kó* ‘(at) which times’ and *tòny kè díi* ‘(with) how many pots’, respectively.

(44) *Ā*-moved adjunct PPs trigger *ké*

- a. Yè **thèek-kó** [_{CP} bji pèel **ké** dhuòŋ]?
 be times-which FUT.OV knives PL break.NF
 ‘At which times will the knives break?’ [Van Urk 2015:168, ex. (81)]
- b. Yè **tóŋny ké** **díi** [_{CP} cji Ból **ké** cuŋin tháal]?
 be pots QUANT.PL how PFV.OV Bol.GEN PL food cook.NF
 ‘How many pots has Bol cooked food with?’ [Van Urk 2015:169, ex. (83b)]

In the next section, we briefly present the vP-phase-based analysis of *ké* developed by Van Urk (2015, 2018) and Van Urk and Richards (2015). We then explore an alternative account of the pattern that attributes it to DP intervention rather than vP phasehood.

3.2. vP-phase account

In a nutshell, Van Urk (2015, 2018) and Van Urk and Richards (2015) propose that *ké* is the realization of an intermediate copy in [Spec,vP], and given that *ké* is obligatory, they conclude that vP must therefore be a phase. Abstracting away from the details of the implementation, they treat the preverbal object position as [Spec,vP], as already mentioned. Because *v* has an EPP requirement, this position must be filled if an object exists. Due to vP’s phasehood, an element that is to be moved out of the vP must first move to this [Spec,vP], from where it can then continue to move to [Spec,CP].¹⁰ If it is plural, this intermediate copy in [Spec,vP] is then realized as *ké*. Because of vP’s phasehood, movement through [Spec,vP]—and hence *ké*—is required in every clause crossed by movement.

This account is elegant and insightful, and it constitutes strong evidence for obligatory successive cyclicity, and vP phases provide a potential analysis. But at the same time, the account faces a number of challenges. The first complication is that *Ā*-extraction of a local external argument does not lead to *ké* (see (42)). All else being equal, this is surprising given that external arguments are typically taken to be base-generated in the phase edge (i.e., [Spec,vP]). As a consequence, they too should leave a copy in [Spec,vP], which we would then expect to be realized as *ké*, contrary to fact. Van Urk (2018:943n5) briefly discusses this challenge and suggests two possible analyses. One is that the external argument is not actually base-generated in [Spec,vP], but in a higher specifier (see also Van Urk 2015:81–82), in contrast to the standard assumption that it is vP that introduces the external argument. The other analysis suggested by Van Urk is that only copies of elements that appear in [Spec,vP] as a result of attraction by (i.e., Agree with) *v* are realized as *ké*. This analysis raises the question how the morphological realization of a copy in [Spec,vP] can be conditioned by whether Merge of this copy was the result of attraction by *v* or not. While these complications are of course surmountable, it is clear that resolving them increases the complexity of the account. What is most significant for our purposes here is that the asymmetry between subjects and objects (with only objects leading to *ké*) does not follow from the vP-phase account as such but requires additional assumptions. In other domains (such as Indonesian and Defaka, to be discussed in section 4), the

¹⁰ Though see Keine (2020b:283–288) for some critical discussion of the role of vP phasehood in this account. Keine argues that the intermediate landing site in [Spec,vP] is already required by *v*’s EPP requirement and that additional appeal to vP phasehood does not make a substantive contribution to Van Urk and Richards’s (2015) and Van Urk’s (2015) account. Here we develop a much more significant reanalysis of the Dinka facts.

existence of a subject–object asymmetry is the key motivation for invoking a clause-medial phase, but at least in Dinka, this asymmetry itself does not seem to directly implicate such a phase.

A second complication concerns the status of unaccusative vP. In Dinka, \bar{A} -extraction of an internal argument of an unaccusative verb does not lead to *ké*, as shown in (45), where movement of *pě̀eɛl-kó* ‘which knives’ does not leave a *ké*.

- (45) *Argument movement out of unaccusative vP does not strand ké*
 Yè [CP **pě̀eɛl-kó** bẹ́ [vP (***ké**) dhuòŋ]]?
 be knives-which FUT (*PL) break.NF
 ‘Which knives will break?’ [Coppe van Urk, p.c.]

At first glance, this restriction might be taken to indicate that unaccusative vP is not a phase and hence that there is no intermediate copy in [Spec,vP] (Chomsky 2000, 2001).¹¹ However, \bar{A} -extraction of a PP adjunct out of such vPs does lead to *ké*, as (46) demonstrates, where movement of *thè̀ek-kó* ‘at which times’ strands *ké*.

- (46) *PP-adjunct movement out of unaccusative vP strands ké*
 Yè [CP **thè̀ek-kó** bíjí pè̀eɛl [vP **ké** dhuòŋ]]?
 be times-which FUT.OV knives PL break.NF
 ‘At which times will the knives break?’ [Van Urk 2015:168, ex. (81)]

On the face of it, the distribution of *ké* indicates that arguments of unaccusatives must exit vP in one-fell-swoop whereas adjuncts must do so successive-cyclically. vP phases themselves do not account for this difference.

In fact, the absence of *ké* in (45) poses a problem for the analysis of why external arguments do not trigger *ké*. As just discussed, Van Urk (2018) sketches two possible approaches to the latter generalization: either (i) the external argument is generated outside of vP or (ii) only copies in [Spec,vP] that are the result of *movement* are realized as *ké*. Neither account generalizes to the fact that unaccusative subjects also do not strand *ké* because they are clearly generated vP-internally and move to [Spec,vP]. Further stipulations are therefore necessary to derive the full distribution of *ké*.

Third, while extraction of a DP argument requires the preverbal position to be empty (seen most clearly with ditransitives, as in (37)), which Van Urk (2015) and Van Urk and Richards (2015) take as evidence for an obligatory intermediate landing site in [Spec,vP], PP extraction is permitted even if this position is filled, as shown in (48).

¹¹ In addition to the empirical point in the main text, it is worth noting that the criterion that phases are propositional units (Chomsky 2000:107, Chomsky 2001:12) does not differentiate between agentive and unaccusative vPs as both are Θ -complete. Chomsky (2001) thus proposes that unaccusative vP is a “weak” phase, which does not induce PIC effects. This distinction between “weak” v and “strong” v does not follow from anything else. Thus, if the absence of *ké* in (45) is attributed to vP being weak here, this is itself a stipulation, and furthermore one that seems to have no counterpart in the CP phase. As we will see, the shift from vP phases to minimality will allow us to dispense with the strong/weak distinction for phases, thereby eliminating the stipulation.

(47) *DP extraction requires empty preverbal position*

a. Yeŋà cǐ mōc _____ yiɛ̀n kitáp?
 who PFV.NSV man.GEN give book
 ‘Who did the man give the book to?’

b. *Yeŋà cǐ mōc kitáp yiɛ̀n?
 who PFV.NSV man.GEN book give
 ‘Who did the man give the book to?’

[Van Urk and Richards 2015:125, ex. (20a,b)]

(48) *PP extraction does not require empty preverbal position*

a. Yeŋó cǐ yìn kôꞗr nɔ̀k?
 what PFV.NSV you lion kill
 ‘What did you kill a lion with?’

b. Yétenô cénnè Ból Dèŋ tuðɔc?
 where PFV.OBLV Bol Deng send
 ‘Where did Bol send Deng?’

[Van Urk and Richards 2015:130, ex. (29b,c)]

If the obligatory preverbal gap with DP extraction in (47) is taken as evidence for an obligatory intermediate landing site in [Spec,vP], then the absence of such a gap with PP extraction in (48) would seem to show that PP extraction does not need to pass through [Spec,vP]. This would constitute evidence *against* vP phases because vP phase would constrain DP and PP movement in the same way. To resolve this paradox, Van Urk (2015) and Van Urk and Richards (2015) propose that PP extraction as in (48) does pass through an intermediate [Spec,vP] but for PPs, this intermediate [Spec,vP] may be an outer [Spec,vP], which coexists with a DP in an inner [Spec,vP] (i.e., *kôꞗr* ‘lion’ and *Dèŋ* ‘Deng’). DP extraction, on the other hand, cannot pass through an outer [Spec,vP] and so the preverbal position must remain empty in (47).¹² While this is a feasible analysis, the fact remains that empirically, the empty-position effect that constituted part of the argument for vP phases fails to obtain for PP extraction. We note that we observed an analogous asymmetry between PPs and DPs in Indonesian, suggesting that this is not purely a Dinka-internal quirk.

3.3. DP-intervention analysis

Because Van Urk’s (2015, 2018) and Van Urk and Richards’s (2015) argument for vP phases in Dinka involves (a) an empty-edge effect in the vP (section 3.1.1) and (b) *ké*-morphology (section 3.1.2), our alternative analysis will need to address both.

We first consider the obligatory emergence of *ké* under \bar{A} -extraction if the object of a transitive clause is moved. We follow Van Urk (2015, 2018) and Van Urk and Richards (2015) in analyzing *ké* as a reflex of successive-cyclic movement but we will argue that this successive cyclicity is better understood as the result of DP intervention rather than phasehood. As for Indonesian, our analysis is based on the guiding view that C in Dinka may only attract the structurally closest DP. Because Dinka is a V2 language and movement to [Spec,CP] hence obligatory, we will adopt what seems

¹² This difference is derived from the Multitasking principle (Van Urk and Richards 2015:132) or Best Match (Van Urk 2015:173).

like the simplest implementation: C bears an EPP property that is nondiscriminating—it does not search for elements with a specific \bar{A} -feature but is instead matched by any DP. The requirement that C attract the closest goal then leads to (49), which is simply an instance of relativized minimality (Rizzi 1990) in Dinka. Alternatively, C in Dinka could contain a complex probe akin to what we proposed for Indonesian (Erlewine 2018, Branan and Erlewine 2021, Coon et al. 2021). But the V2 character of C in Dinka makes a simpler, purely EPP-based account viable, which we will adopt here.

(49) Dinka C bears an [EPP] feature that may attract only the structurally closest DP.

At first glance, (49) appears empirically incorrect. Clearly, it is possible for elements other than the local subject (which is structurally closest to C) to occupy [Spec,CP]. But it is precisely in such cases that *ké* must appear, which suggests that the two are connected. We thus propose that such cases involve leapfrogging as in Indonesian: the lower DP first moves across the external argument, after which it can then be attracted by C. We then analyze *ké* as the reflex of the probe that gives rise to this leapfrogging.

To develop this idea, we assume, following Van Urk (2015), that subjects undergo movement to [Spec,TP] in Dinka. Van Urk (2015:86–87) shows that subjects that occur in the middle field (that is, subjects that do not raise to [Spec,CP]) follow the verb in the V2 position, irrespective of whether the verb is unaccusative, unergative, or transitive, as illustrated in (50).

- (50) a. Bέ **lēc** dhuōŋ?
 FUT.SV stick.GEN break.NF
 ‘Will the sick break?’
- b. Bέ **Ból** càŋ (ẹ cuḷin)?
 FUT.SV Bol.GEN eat.AP.NF P food
 ‘Will Bol eat food?’

Furthermore, this position of the subject precedes vP-level adverbs such as *dâac* ‘quickly’:

- (51) Bέ **lēc** dâac dhuōŋ?
 FUT.SV stick.GEN quickly.NF break.NF
 ‘Will the stick break quickly?’

Van Urk (2015:87) suggests that these placement facts are explained if subjects move to [Spec,TP] in Dinka, a view that we adopt here as well. Associating middle-field subjects with a designated position also offers an account of the fact that they appear with genitive (Van Urk 2015, 2018) case (or oblique case, see Andersen 2002, 2007), but objects do not (Van Urk 2015:71–73, 86–89). If genitive case is assigned to elements in [Spec,TP], then the claim that middle-field subjects move to [Spec,TP] offers an immediate explanation for why they uniformly bear genitive case. We therefore assume that T bears a standard [EPP] feature that is satisfied by moving a DP into its specifier.¹³

¹³ It does not matter for our analysis why or how elements in [Spec,TP] receive genitive case. Perhaps the most straightforward option is that genitive is assigned by T in Dinka and hence correlates with movement to the subject position. Alternatively, Van Urk (2015:86–92) proposes that genitive case is assigned by a silent P head that is late-merged to a DP

In light of the restriction in (49), movement of an element other than the subject requires leapfrogging of this element around the subject in [Spec,TP], by assumption to an outer specifier of T. Note that the landing site of the leapfrogging step thus differs from what we proposed for Indonesian (where leapfrogging targets an outer [Spec,vP]). This difference follows from the different position of subjects in the two languages, with Dinka subjects moving to [Spec,TP] (see (50)/(51) vs. (16)). A second difference between Dinka and Indonesian is that we propose that in Dinka is not triggered by a [$u\delta$]-feature but by a strong φ -probe [$u\varphi$]. This φ -probe agrees with the closest φ -bearing element c-commanded by T (after subject raising to [Spec,TP]) and attracts this element to [Spec,TP]. This feature is what underlies *ké*. Specifically, we analyze *ké* as the realization of plural agreement with [$u\varphi$], as stated in (52).

(52) /*ké*/ ↔ [PL]

In contrast to Van Urk (2015, 2018) and Van Urk and Richards (2015), we hence do not analyze *ké* as the realization of an intermediate copy, but rather as agreement on T.¹⁴ We thus treat the form identity between the pronoun *ké* and the successive-cyclicity marker *ké* as an instance of syncretism: despite the fact that the two are syntactically distinct, they are both realized by the vocabulary item in (52), which realizes a [PL] feature but is underspecified with respect to the part of speech of the node (D vs. T). As such, the identity between the two elements is not an instance of accidental homophony, but it is stated at the level of the vocabulary item, not at the level of the syntactic structure that it realizes.

The gist of this analysis is that *ké* is the realization of a verbal φ -probe that is connected to movement of the goal. This analysis finds a clear analogue in Romance (past) participle agreement, which is tied to extraction of the goal out of the vP (see Belletti 2017 and references cited there). An Italian example is provided in (53). In the passive construction (53b), the verb agrees with the promoted internal argument *Maria*. This contrasts with the active-clause baseline in (53a), in which the participle does not agree.

- (53) a. *Maria ha assunto Susanna.*
 Maria has hired Susanna
 ‘Maria has hired Susanna.’ [Daniele Panizza, p.c.]
- b. *Maria è stata assunta.*
 Maria be.3SG been.F.SG hired.F.SG
 ‘Maria has been hired.’ [Belletti 2017:2975, ex. (3)]

in [Spec,TP] as a last-resort mechanism to assign case. A third possibility, pointed out to us by a reviewer, is that these clauses are in fact nominalized and genitive case is licensed by this nominalizing structure. Because case does not play a role in our analysis of the *ké*-facts, nothing hinges on the choice between these options.

¹⁴ Van Urk (2015:217, 2018:948) notes that treating *ké* as the realization of a head in the clausal spine would require violating the Head Movement Constraint (Travis 1984) because it is possible for the main verb to move over it to a V2 position. However, much recent work has shown that there are several cases of head movement that descriptively violate the Head Movement Constraint (e.g., Rivero 1994, Roberts 1994, Harizanov 2019, Harizanov and Gribanova 2019), so Dinka would in no way be exceptional in this regard. Moreover, excorporation analyses of head movement have been proposed by Roberts (1991, 2010). These analyses are compatible with treating *ké* as the realization of a verbal head.

Participle agreement appears in a range of configurations, which Kayne (1989) correlates with A-extraction of the internal argument (as an instance of Spec–Head agreement, Kayne proposes). Our analysis of *ké* is similar in this regard. Arabic subject–verb agreement (where only preverbal subjects control number agreement; Harbert and Bahloul 2002) provides a related example of φ -agreement that correlates with movement (also see Zeijlstra 2012 and Bjorkman and Zeijlstra 2019).

T therefore bears two features: [EPP] and optionally a strong [$u\varphi$]. These two features are ordered such that if both are present, [EPP] applies before [$u\varphi$]. [EPP] has the standard effect of moving the closest DP to the subject position; [$u\varphi$], if present, leads to leapfrogging of the next-higher DP around the subject. Let us first consider an example in which [$u\varphi$] is absent. Such structures will lead to movement of the subject to [Spec,CP] with no *ké*. An example is provided in (54), and the corresponding structure is shown in (57).

- (54) **رؤوور** áa-cé (***ké**) yîin tîiη.
 men 3P-PFV (*PL) you see.NF
 ‘The men have seen you.’

[Van Urk 2018:950, ex. (25a)]

- (55) *Derivation of (54)*

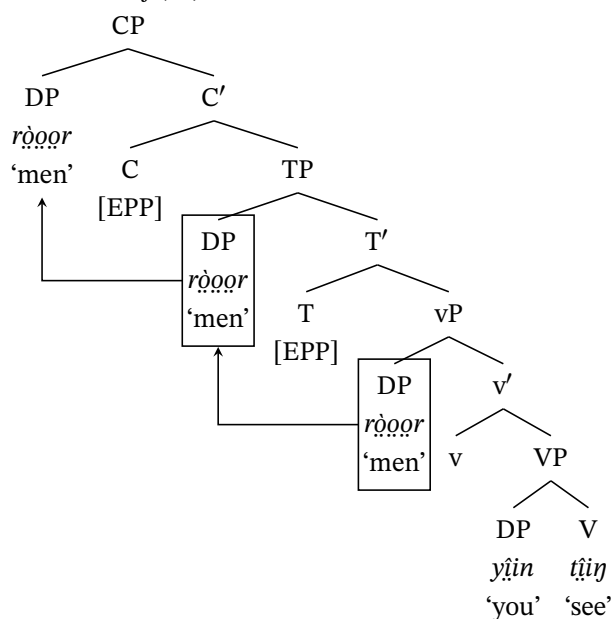

In (55), T bears only [EPP], which leads to standard raising of the external argument *رؤوور* ‘men’ to [Spec,TP]. Because T does not bear [$u\varphi$], T does not agree with another element, and it does not establish φ -Agree with a DP. As a result, *رؤوور* is the closest DP to C, and as a result it is attracted to [Spec,CP] to satisfy C’s [EPP] feature.

Next, we contrast this derivation with one in which T bears not only [EPP], but also [$u\varphi$]. As we show, this setup will lead to movement of an element other than the subject to [Spec,CP] and to *ké* if this element is plural. A sentence that illustrates such a structure is repeated in (56).

- (56) **Yeyiṅà** c̣i Ból **ké** ṭiṅ?
 who.PL PFV.NSV Bol.GEN PL see
 ‘Who all did Bol see?’

[Van Urk and Richards 2015:127, ex. (23b)]

As shown in (57), [EPP] on T triggers movement of the external argument *Ból* to [Spec,TP], as before. Because in this case T additionally bears $[u\phi]$, $[u\phi]$ agrees with the closest DP in its c-command domain—in this case the internal argument *yeyiṅà* ‘who.PL’—and attracts it to an outer [Spec,TP]. This leapfrogging is accompanied by plural agreement on $[u\phi]$, realized as *ké*. Finally, C attracts the structurally closest element, which in (57) is the leapfrogged object *yeyiṅà*.

- (57) *Derivation of (56)*

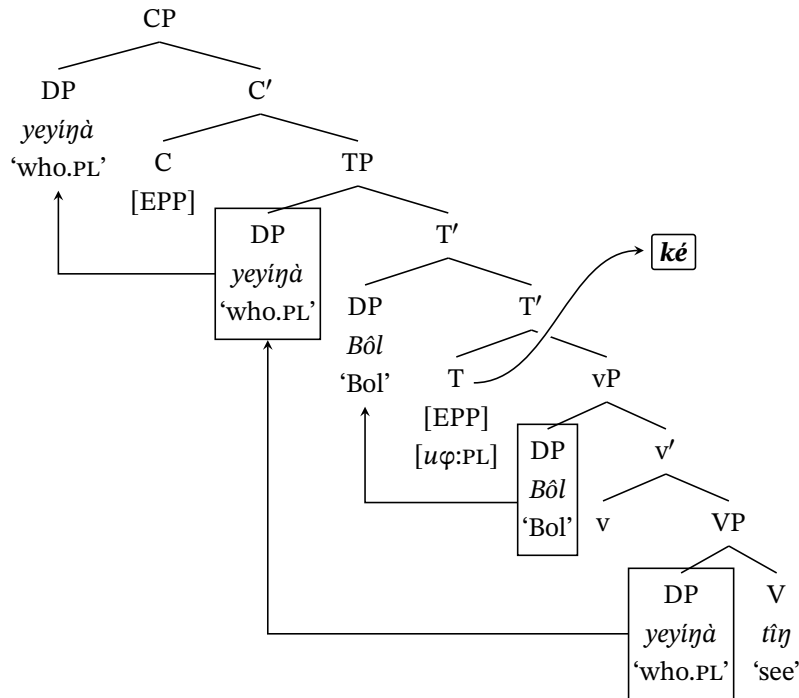

It is important that $[u\phi]$ cannot agree with the subject in [Spec,TP], or else a plural subject could trigger *ké*. There may be at least two principled reasons for this. First, if Agree is downward-only (Chomsky 2000, 2001), then it follows that a probe on T must agree with an element in its c-command domain, hence within the vP. Because probing by T's [EPP] applies before probing by $[u\phi]$ and thus moves the external argument out of $[u\phi]$'s c-command domain, $[u\phi]$ can then never agree with the external argument. Second, as already noted, it is a general property of Dinka that subjects that occur in [Spec,TP] bear genitive case. If ϕ -valuation is case-discriminating (Bobaljik 2008, Preminger 2014) in the sense that it may not target genitive DPs, then it also follows that $[u\phi]$ cannot be valued by a subject in [Spec,TP]. As a result, if $[u\phi]$ is present on T, it must be valued by an element other than the subject, leading to leapfrogging of this element over the subject.

We note that this analysis does not involve lookahead. $[u\phi]$ may be either present on or absent from T, the choice being free but with different outcomes in each case. If T does not bear $[u\phi]$, then (i) no ϕ -Agree will be established and hence *ké* will be absent, (ii) no leapfrogging of an element over

the subject takes place, and as a result, (iii) it is the subject that is attracted to [Spec,CP]. Conversely, if T bears [$u\phi$], then (i) the highest vP-internal element will control ϕ -Agree on T, leading to *ké* if it is plural, (ii) this element will leapfrog over the subject to an outer [Spec,TP], and (iii) being closer to C than the subject, it is this leapfrogged element that moves to [Spec,CP]. Furthermore, we emphasize that this analysis does not invoke vP phasehood in any way. First, the intermediate landing site is located in [Spec,TP] rather than [Spec,vP]; second, the need for this intermediate landing site is not related to phasehood but to DP intervention.

This analysis of *ké* as the realization of plural agreement on *v* also accounts for the fact that while *ké* appears only if the \bar{A} -extracted element is plural, it is insensitive to the person of the moving element, and also appears with 1st and 2nd person plural objects (see (40)). The absence of person marking seems more problematic if *ké* is analyzed as a pronoun that realizes an intermediate landing site, though see Van Urk (2018:960–974) for an analysis.

Let us turn next to the empty-position effect, seen most clearly with ditransitive verbs (see section 3.1). Recall that in such constructions, one object must appear before the verb and one following the verb (see (58)). Furthermore, if \bar{A} -movement of an object out of this vP takes place, it must empty the preverbal position and cannot empty the postverbal position (see (59)).

- (58) a. $\forall\epsilon\epsilon\text{n } c\acute{e} \text{ Ayén } y\grave{i}\grave{n} \text{ k}\grave{i}\text{t}\acute{a}\text{p}.$
 I PFV Ayen give book
 b. $\forall\epsilon\epsilon\text{n } c\acute{e} \text{ k}\grave{i}\text{t}\acute{a}\text{p } y\grave{i}\grave{n} \text{ Ayén}.$
 I PFV book give Ayen
 ‘I gave Ayen a book.’ [Van Urk and Richards 2015:124–125, ex. (19a,b)]

- (59) a. $Y\epsilon\eta\grave{a}_1 \text{ c}\acute{i}\grave{i} \text{ m}\acute{o}\text{c} \text{ ___}_1 \text{ y}\grave{i}\grave{n} \text{ k}\grave{i}\text{t}\acute{a}\text{p}?$
 who PFV.NSV man.GEN give book
 ‘Who did the man give the book to?’
 b. $*Y\epsilon\eta\acute{o}_1 \text{ c}\acute{i}\grave{i} \text{ m}\acute{o}\text{c} \text{ Ayén } y\grave{i}\grave{n} \text{ ___}_1?$
 what PFV.NSV man.GEN Ayen give
 ‘What did the man give Ayen?’ [Van Urk and Richards 2015:125, ex. (20a,d)]

As noted in section 3.1, Van Urk (2015, 2018) and Van Urk and Richards (2015) analyze this restriction in terms of vP phases. On their analysis, *v* bears an EPP property, requiring one of the two objects to move to [Spec,vP]. Subsequent \bar{A} -movement can then only target this element, not the VP-internal, postverbal object. Interestingly, Van Urk (2015:151–154) argues that in structures like (58a,b) derive from different base configurations, as shown in (60) and (61) (Van Urk 2015:153, 154). In both configurations, only the structurally closer element may move to [Spec,vP].

- (60) *Van Urk’s (2015) structure for (58a)*

$$\begin{array}{c} \downarrow \\ [_{VP} \text{ Ayén } v^0 [_{AppIP} t \text{ AppI}^0 [_{VP} y\grave{i}\grave{n} \text{ k}\grave{i}\text{t}\acute{a}\text{p}]]] \\ \text{Ayen} \qquad \qquad \qquad \text{give book} \end{array}$$

(61) *Van Urk's (2015) structure for (58b)*

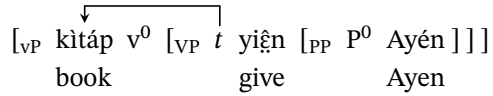

In these structures, the displacement to [Spec,vP] is string-vacuous, driven only by the assumption that vP is a phase. If we question this assumption, the possibility emerges that in fact no displacement to [Spec,vP] takes place in (60) and (61) and that the two object DPs remain in their base positions. Let us suppose so. Let us furthermore suppose that [$u\varphi$] on T may only agree with the closest φ -bearing element, a standard instance of relativized minimality, as stated in (62).

(62) [$u\varphi$] on T attracts the structurally closest φ -bearing element in its c-command domain.

Recall that the external argument does not count for (62), either because it is attracted to [Spec,TP] by [EPP] before [$u\varphi$] probes its c-command domain, or because its genitive case prevents it from being attracted by [$u\varphi$]. We also note that (62) is analogous to the “closest” requirement of C in Dinka (49) and Indonesian (18). This generalizes the core of our account to heads other than C.

(62) has the consequence that if v’s search space contains two φ -bearing DPs, only the higher one may be attracted and hence leapfrog over the external argument. In ditransitive constructions, only the higher object may therefore move to [Spec,CP] (as such movement requires leapfrogging over the external argument). This is schematized in (63), where [$u\varphi$] may only attract the higher object *yeηá* ‘who’ to the outer [Spec,TP], yielding (59a). The postverbal object could not be attracted by [$u\varphi$] due to intervention by the higher object, correctly ruling out (59b). This derives the contrast in (59) from Van Urk’s (2015) structure for ditransitives and relativized minimality in the probing of [$u\varphi$] (i.e., (62)) and explains why extraction can only produce a preverbal gap in (59). Unlike Van Urk’s (2015) and Van Urk and Richards’s (2015) account, we identify this gap with the base position of the object, not an intermediate landing site.

(63) Derivation of (59a)

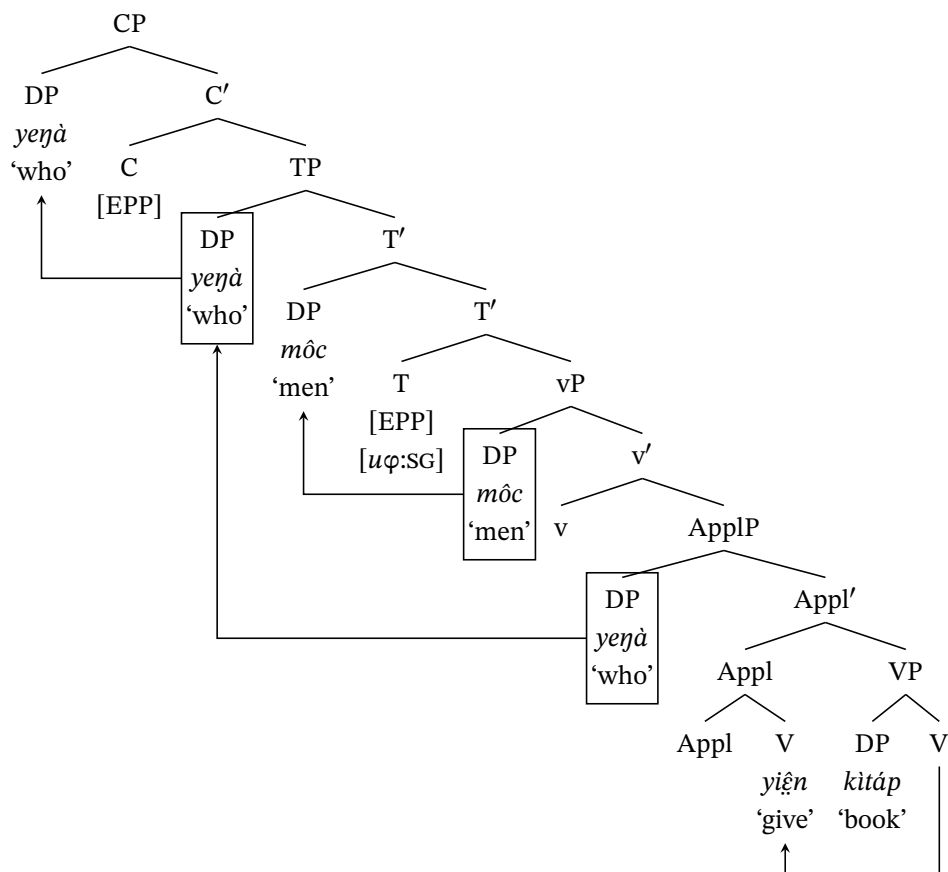

This treatment of extraction in ditransitive constructions raises a question about the placement of the verb relative to other elements, to which we now turn. In transitive sentences without movement of the object, the verb follows the object. But in a ditransitive structure, the verb is sandwiched between the two objects. We suggest that this difference is the result of verb raising in ditransitive constructions.¹⁵ Specifically, the Appl head that is present in ditransitive constructions triggers head movement of V to it, resulting in VO word order, as indicated in (63). Monotransitives do not contain an Appl projection and so V remains in its base position, yielding an OV order.

Our proposal that the immediately preverbal gap position that arises under object \bar{A} -movement as in (64) is not [Spec,vP], but simply the base position of the object, not only simplifies the syntax underlying object placement in Dinka, it also allows us to account for the appearance of the preverbal gap position in (64) without appeal to intermediate movement through [Spec,vP] and hence vP phases.

- (64) Yeηà₁ cĭ môt ___₁ yiæn kitáp?
 who PFV.NSV man.GEN give book
 ‘Who did the man give the book to?’

[Van Urk and Richards 2015:125, ex. (20a)]

¹⁵ We thank a reviewer for suggesting this analysis.

This analysis extends to ditransitive constructions like (58b) in which the preverbal position is occupied by the theme argument and the recipient appears postverbally. Here as well, only the preverbal object may undergo \bar{A} -movement (see Van Urk and Richards 2015:125, ex. (20c,d)). We draw again on Van Urk's (2015) analysis of these constructions, assuming the structure in (65). See Van Urk (2015) for evidence that the postverbal element in these constructions is a PP rather than a DP.

- (65) [_{VP} kitáp [yìɛ̃n [_{PP} P⁰ Ayén]]]
 book give Ayen

As before, due to (62), [$u\varphi$] on T can attract only the higher object. Consequently, the lower PP object cannot leapfrog over the subject and hence cannot undergo \bar{A} -movement.

Again, we need to ask why the verb's PP complement is linearized to the right in (65) instead of to the left. As it turns out, this is a general property of PPs in the language, also observable outside of ditransitive constructions. We already saw this for locative PPs in (35), repeated here as (66). The same holds for PPs that cooccur with direct objects, as in (67).

- (66) a. Wɔ̀ɔk cɛ̃ ____ kɛ̃t dòm-íc.
 we PFV sing garden-in
 'We sang in the garden.'
- b. *Wɔ̀ɔk cɛ̃ dòm-íc kɛ̃t.
 we PFV garden-in sing
 'We sang in the garden.' [Van Urk and Richards 2015:123, ex. (17a,b)]

- (67) a. Àyén à-cɛ̃ cũɪ̃n câam [_{PP} nɛ̃ pǎal]
 Ayen 3SG-PFV food eat.NF P knife
 'Ayen has eaten food with a knife.'
- b. *Àyén à-cɛ̃ cũɪ̃n [_{PP} nɛ̃ pǎal] câam
 Ayen 3SG-PFV food P knife eat.NF
- c. *Àyén à-cɛ̃ [_{PP} nɛ̃ pǎal] cũɪ̃n câam
 Ayen 3SG-PFV P knife food eat.NF [Van Urk 2015:79–80, ex. (42a–c)]

Thus, PPs are linearized to the right when they occur inside vP. This general property of PPs then immediately explains the word order in (65).

The restriction in (62) that, like [EPP] on C, [$u\varphi$] on T can only agree with, and attract, the structurally closest element explains not only the extraction restrictions in ditransitive constructions, but also extends to constraints on crossclausal extraction. As (68a) shows, it is possible for the verb *lɛ̃k* 'tell' to take a CP argument and a structurally higher indirect object (*Dɛ̃ɲ*). (68b) then demonstrates that long \bar{A} -movement out of the embedded CP cannot cross the intervening *Dɛ̃ɲ*.

- (68) a. Yà̃ar à-cɛ̃ Dɛ̃ɲ lɛ̃k, [_{CP} yè Bòl à-cɛ̃ Ayén tuòɔc wù̃ɪ̃t]
 Yaar 3SG-PFV Deng tell C Bol 3SG-PFV Ayen send cattle.camp.LOC
 'Yaar told Deng that Bol sent Ayen to the cattle camp.'

- b. **Yeŋà cǐi Yâar Dèŋ lɛ̀k*, [_{CP} *yè cǐi Ból tuòc*
 who PFV.NSV Yaar.GEN Deng tell C PFV.NSV Bol.GEN send
wúut]?
 cattle.camp.LOC
 ‘Who did Yaar tell Deng that Bol sent to the cattle camp?’

[Van Urk and Richards 2015:133, ex. (37a,c)]

Our DP-intervention account derives the ungrammaticality of (68b) from (62), as shown in (69). Movement of *yeŋà* to the matrix [Spec,CP] requires leapfrogging around the matrix subject *Yâar*, hence Agree with the matrix [*uφ*]. But because the indirect object *Dèŋ* intervenes between [*uφ*] and *yeŋà* inside the embedded CP, [*uφ*] cannot agree with *yeŋà*. As a result, matrix C cannot attract *yeŋà*, ruling out (68b).

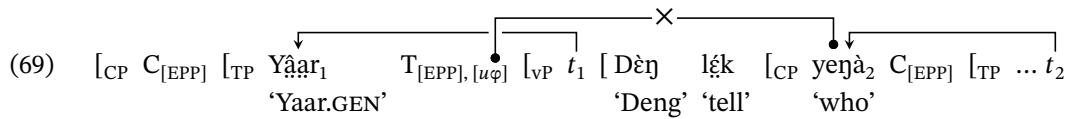

Our analysis thus attributes the crossclausal extraction restriction in (68) to the same constraint that restricts extraction in ditransitive constructions (59)—only the DP closest to T can undergo leapfrogging to an outer [Spec,TP]. And this restriction is in turn due to the same constraint that gives rise to the need for leapfrogging in the first place—the relevant probes on C and T can agree only with the structurally closest element (i.e., (49) and (62)).

On our analysis, then, the empty preverbal position created by \bar{A} -movement of a DP—one of the key arguments for clause-medial phasehood presented by Van Urk (2015) and Van Urk and Richards (2015)—does not reflect an intermediate phase edge after all, but the base position the DP. An important advantage of this shift in perspective is that it immediately resolves a puzzle that arises with PP extraction. As discussed in section 3.2, PP extraction differs from DP extraction in that it does *not* empty the preverbal position. In the examples in (70), movement of the PPs *yeŋô* ‘(with) what’ and *yétenô* ‘where’ is possible despite the preverbal position being filled by *kôor* ‘lion’ and *Dèŋ* ‘Deng’, respectively. We follow Van Urk (2015:169) in assuming that the locative PP of *tuòc* ‘send’ is an adjunct. The fact that PP extraction does not require the preverbal position to be empty in (70) directly contrasts with ditransitive constructions like (59).

- (70) a. *Yeŋô cǐi yìn kôor nɔ̀k?*
 what PFV.NSV you lion kill
 ‘What did you kill a lion with?’
- b. *Yétenô cénne Ból Dèŋ tuòc?*
 where PFV.OBLV Bol Deng send
 ‘Where did Bol send Deng?’

[Van Urk and Richards 2015:130, ex. (29b,c)]

On Van Urk and Richards’s (2015) and Van Urk’s (2015) vP-phase account, where the preverbal position is [Spec,vP] and must be targeted by intermediate movement due to vP phasehood, the fact that PPs apparently do not need to pass through this [Spec,vP] requires additional assumptions. On the account we propose here, (70) follows without additional assumptions to this effect. This

is because the base position of these PP elements, like that of all PPs (see (66)–(67)), is invariably postverbal, as shown for *tuòc* ‘send’ in (71).

- (71) a. Bòl à-cẹ̀ Dèη tuòc **wúút**.
 Bol 3SG-PFV Deng send cattle.camp.LOC
 ‘Bol sent Deng to the cattle camp.’
- b. *Bòl à-cẹ̀ **wúút** tuòc Dèη.
 Bol 3SG-PFV cattle.camp.LOC send Deng
 ‘Bol sent Deng to the cattle camp.’ [Van Urk and Richards 2015:129, ex. (28a,b)]

If the preverbal gap in (64) does not reflect an intermediate landing site in [Spec,vP] but instead the base position of the extracted element, as we have proposed, then it follows without further ado that PP extraction does not give rise to a preverbal gap, simply because the base position of a PP can never be preverbal. The relevant gap in (70) is thus necessarily in a postverbal position and does not affect the order of preverbal elements. This explanation is of course available only if the empty-position effect in cases like (64) is dissociated from vP or vP phasehood.

While PP extraction hence does not result in a preverbal gap, it does yield *ké* if the element is plural, as shown in (72).

- (72) *PP extraction strands ké*
- a. Yè **tòny** **ké** **díi** [_{CP} cị̀ Bòl **ké** cuị̀n tháal]?
 be pots QUANT.PL how PFV.OV Bol.GEN PL food cook.NF
 ‘How many pots has Bol cooked food with?’
- b. Yè **uáan-kó** cị̀ Bòl **ké** Àyén tuòc?
 be places-which PFV.OV Bol.GEN PL Ayen send.NF
 ‘Which places has Bol sent Ayen to?’ [Van Urk 2015:169, ex. (83a,b)]

The reason that *ké* arises here is the same as with DP extraction: in order for the PP to be attracted to [Spec,CP], it must be the closest element to C. This requires leapfrogging over the subject and hence Agree with T’s [*uφ*]. One question that arises, of course, is why [*uφ*] should be able to agree in number with a PP. This is likely related to another curious property of PP \bar{A} -movement in Dinka, discussed in detail by Van Urk (2015). As Van Urk shows, these elements appear with a preposition in their postverbal base position, but if they undergo \bar{A} -movement, the preposition disappears and the remaining DP receives case from C. This is illustrated in (73). In (73a), *nẹ̀ tòny* ‘with a pot’ appears in its base position and bears the preposition *nẹ̀* ‘with’. (73b) shows that if this element is \bar{A} -moved, this preposition disappears.

- (73) a. Bòl à-thẹ̀t **nẹ̀ tòny**.
 Bol 3P-cook.SV P pot
 ‘Bol is cooking with a pot.’
- b. **Tòny** à-thẹ̀gtẹ̀ Bòl.
 pot 3P-cook.OBLV Bol.GEN
 ‘A pot, Bol is cooking with.’ [Van Urk 2015:105, ex. (25a,b)]

Van Urk (2015:74–78) proposes that the preposition *nɛ* incorporates into C while the DP moves into [Spec,CP]. Another possibility, mentioned in Van Urk (2015:77–78, 2018:949n13), is that *tɔ̀ny* in (73) is base-generated as a DP in an applicative construction (and that such a configuration violates the Case Filter unless the DP is extracted to [Spec,CP]). The choice does not matter for our analysis. For the sake of concreteness, we will treat these DPs/PPs as adjuncts and assume that the φ -features of the DP inside the adjunct are visible to T's φ -probe. Following Van Urk (2015, 2018) and Van Urk and Richards (2015), we take the base position of such elements to be within the vP and lower than the external argument, either as adjuncts or in an applicative structure.

Assuming, therefore, that [$u\varphi$] can agree with PPs as a result of their DP-like properties under \bar{A} -movement (in whichever way these are derived), our analysis derives *ké*-stranding in (72) directly. To illustrate using (72a), in order for C to attract *tɔ̀ny kɛ dii* '(with) how many pots', this element needs to be moved over the external argument, which in turn requires Agree with T's [$u\varphi$]. In (74), *tɔ̀ny kɛ dii* '(with) how many pots' is the structurally closest φ -bearing element to T and so it is attracted to an outer [Spec,TP], from where it undergoes movement to [Spec,CP]. Since *tɔ̀ny kɛ dii* '(with) how many pots' is plural, *ké* results. Note that, in line with (62), T attracts the structurally closest φ -bearing element in (74). The direct object *cu̱in* 'food' linearly intervenes but not structurally.¹⁶

(74) Derivation of (72a)

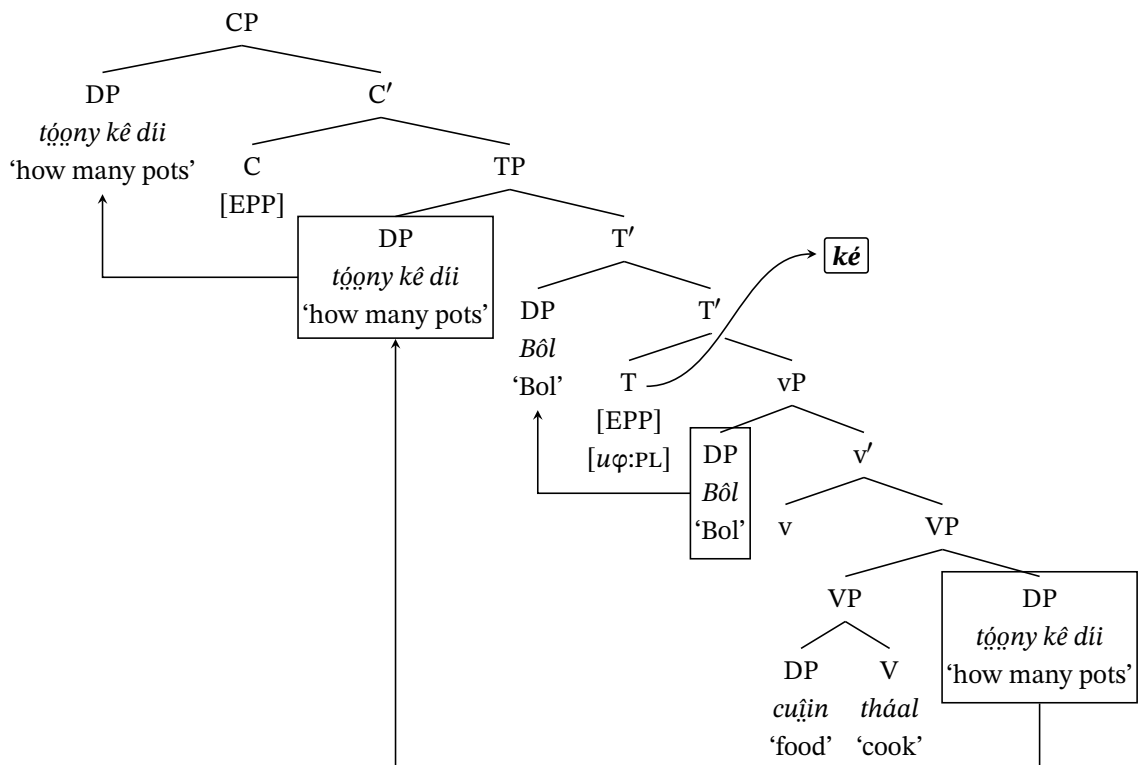

¹⁶ On our account, *ké* is thus in the same position in all its occurrences, namely in T. This differs from the account in Van Urk (2015, 2018) and Van Urk and Richards (2015), which locates *ké* in an inner [Spec,vP] if the moving element is a DP but in an outer [Spec,vP] if the moving element is a PP. We do not know of a way to empirically distinguish between these two views.

We note that the presence of an adjunct does not interfere with \bar{A} -movement of an object (see Van Urk 2015:61, 2018:942). This follows from the assumption that the base position of adjuncts is variable and hence may be lower than the position of verbal arguments (Larson 1988, 2004, Pesetsky 1995, Lechner 2003, Csirmaz 2005:90–98).¹⁷

Finally, this leapfrogging account resolves the problem that unaccusative structures pose for a vP-phase account. Recall from (45), repeated here as (75), that \bar{A} -extraction of the subject of an unaccusative does not lead to *ké*.

- (75) Yè [_{CP} pǝǝl-kó bǝ (*kǝ) dhuðoŋ]?
 be knives-which FUT (*PL) break.NF
 ‘Which knives will break?’ [Coppe van Urk, p.c.]

At the same time, extraction of an adjunct out of an unaccusative vP does induce *ké* if plural, as shown again in (76), repeated from (46).

- (76) Yè [_{CP} thǝǝk-kó bǝi pǝǝl kǝ dhuðoŋ]?
 be times-which FUT.OV knives PL break.NF
 ‘At which times will the knives break?’ [Van Urk 2015:168, ex. (81)]

As noted in section 3.2, on a vP-phase account, the contrast between (75) and (76) is puzzling. If *ké* indicates successive-cyclic movement through [Spec,vP], then (75) would show that unaccusative vP acts as a phase for extraction of the unaccusative subject in (76) but not for the extraction of the adjunct in (75). This would result in a contradiction: how can the same vP act as a phase in (76) but not in (75)? Because our leapfrogging account attributes the emergence of *ké* to intervention rather than to phasehood, it offers an immediate solution to this puzzle. The derivation of (76) is analogous to (74) in the relevant respects, as shown in (77). The unaccusative subject *pǝǝl* ‘knives’ moves to [Spec,TP], where it intervenes between C and *thǝǝk-kó* ‘which times’. In order for *thǝǝk-kó* ‘which times’ to be movable to [Spec,CP], it must leapfrog around the subject and hence agree with [*uφ*] on T, resulting in *kǝ*.

- (77) Derivation of (76): leapfrogging required
-
- [_{CP} thǝǝk-kó C_[EPP] [_{TP} t [_{T'} pǝǝl T_{[EPP], [uφ]} [_{vP} t dhuðoŋ t]]]]
- ‘which times’ ‘knives’ ‘break’

By contrast, in (75), it is the unaccusative subject itself that undergoes movement to [Spec,CP]. This is possible only if no leapfrogging around the subject takes place. The relevant derivation for (75) is shown in (77). In this case, it is irrelevant whether T contains [*uφ*] or not (indicated with parentheses in (77)). In either case, [EPP] applies first, moving the DP *pǝǝl-kó* ‘which knives’ to [Spec,TP], followed by movement to [Spec,CP]. If T contains [*uφ*], it fails to agree in (77) because

¹⁷ In principle, we predict that structurally higher adverbs, in particular ones that are generated vP-externally, should be able to front without triggering *ké* because they are not dependent on leapfrogging and hence [*uφ*]. Unfortunately, it seems impossible to assess this prediction because *ké* is generally only triggered by plural elements. Adverbs do not meet this requirement and so are not expected to give rise to *ké* in any case.

its c-command domain (i.e., the vP) does not contain a licit agreement target. Consequently, no *ké* arises regardless of whether [*uφ*] is present on T in (77) or not.

(78) *Derivation of (75): no leapfrogging required*

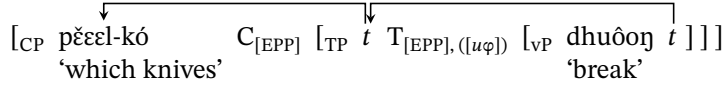

To summarize this section, the alternative analysis we proposed does not appeal to clause-medial phases in any way but instead derives the pattern from intervention and the concomitant need for leapfrogging. As in our account of Indonesian, the key component of the analysis is that C in Dinka may only attract the closest goal. For an element other than the closest one to be attracted by C, it must first move around the highest DP. We have analyzed *ké* as the realization of the probe that gives rise to this movement. This analysis does not involve a clause-internal phase and the Dinka pattern therefore no longer provides evidence for the existence of such a phase. We showed how the shift from phasehood to intervention allows us to (i) explain why local subjects do not strand *ké* under \bar{A} -movement, which we saw requires additional assumptions on a vP-phase account and (ii) understand the otherwise paradoxical behavior of unaccusative vPs with respect to *ké*. We also showed that the extraction restriction in ditransitive constructions can be given an analogous account—[*uφ*] on T may only attract the structurally closest DP. The crucial locality property of C thus also holds for other heads in the language, paving the way for a uniform account of the various components of Dinka’s complex \bar{A} -extraction system in terms of DP intervention. Finally, our analysis locates the intermediate landing site in an outer [Spec,TP] in Dinka, whereas we located the landing site in an outer [Spec,vP] in Indonesian. This difference correlates with the position of subjects in the two languages: vP in Indonesian, TP in Dinka. The connection between the location of the subject and the height of the intermediate landing site follows immediately from a DP-intervention account but not a clause-medial phase account. Furthermore, even proposals that allow clause-medial phases to occur higher than vP, such as Bošković (2014) and Harwood (2015), nonetheless locate it below T, which is still too low for our analysis of Dinka. The next section argues that in Defaka, the position of the intermediate landing site is even higher than TP.

4. Extraction morphology in Defaka

An important difference between a phase-based account of clause-medial successive cyclicity and our intervention-based reanalysis is that on a phase-based account, all else equal, the intermediate landing site is expected to be constant across languages (assuming that phasehood is crosslinguistically stable). On an intervention-based account, the intermediate landing site is conditioned by wherever the intervening subject is located: vP in Indonesian, TP in Dinka. In this section, we argue that clause-medial successive cyclicity can target an even higher position if the subject is sufficiently high. We make this case based on extraction morphology in Defaka, where the subject undergoes movement to a TP-external position (Bennett 2009, Bennett et al. 2012) and, we argue, successive cyclicity correspondingly targets a very high position.

4.1. Empirical evidence

Defaka is an SOV language that allows focus fronting of maximally one XP. This fronting has morphological effects. As shown in (79b), when a local subject is focus-fronted, it bears a focus marker *kò*; the verb morphology remains unaffected. When any element other than the local subject undergoes focus fronting, two reflexes arise, illustrated in (79c). First, the fronted XP bears the focus marker *ndò*. Second, the verb bears the special morphological marker *kè*. In what follows, we simply gloss *kè* as “KE” in the examples. We follow Bennett (2009) and Bennett et al. (2012) in glossing *kò* as “FOC.SBJ” but as we will see immediately below, *kò* appears only if it is the *local* subject that has undergone focus fronting.¹⁸

- (79) a. *No focus-fronting*
 ì Bòmá ésé-kà-rè
 I Boma see-FUT-NEG
 ‘I will not see Boma.’
- b. *Local-subject focus*
 ì **kò** Bòmá ésé-kà-rè
 I FOC.SBJ Boma see-FUT-NEG
 ‘I will not see Boma.’
- c. *Object focus*
 Bòmá **ndò** ì ésé-kà-rè-**kè**
 Boma FOC I see-FUT-NEG-KE
 ‘I will not see Boma.’ [Bennett et al. 2012:294, ex. (1)–(3)]

Importantly, the split sets local subjects apart from all other fronted elements. That is, fronting of adjuncts patterns like fronting of objects, as shown in (80): the fronted XP bears *ndò*, and the verb bears *kè*. This includes locative adverbs and temporal adverbs.

- (80) *Adjunct focus* → *kè*
- a. [ándù kikià] **ndò** à èbèrè rì bòi-mà-**kè**
 canoe under FOC the dog KE hide-NFUT-KE
 ‘The dog is hiding under the canoe.’ [Bennett et al. 2012:296, ex. (15)]
- b. òmòmò **ndò** Bòmá ìbò tìnà árí-**kè**
 now FOC Boma big fish catch-KE
 ‘Boma caught a big fish just now.’ [Bennett 2009:18, ex. (59b)]
- c. [nùmá bíò] **ndò** ò à tìnà árí-**kè**
 that river FOC he the fish catch-KE
 ‘He caught the fish in that river.’ [Bennett 2009:18, ex. (61b)]

¹⁸ In order to stay as close as possible to the original examples as possible, we maintain Bennett’s (2009) and Bennett et al.’s (2012) convention of indicating focus by means of underlining in the free translation.

Long focus fronting is possible, and in this case, *kè* arises in the way just described on all verbs crossed by movement. If an object is moved nonlocally, both the embedded verb and the matrix verb bear *kè*, as (81) shows.

(81) *Nonlocal-object focus*

ándù₁ **ndò** Bòmá fàà-**kè** [_{CP} iní ___₁ été-**kè**]
 canoe FOC Boma say-KE they have-KE

‘It’s a canoe that Boma said that they have.’

[Bennett et al. 2012:297, ex. (21)]

If an embedded subject is fronted nonlocally, *kè* does not appear on the embedded verb, but it must appear on the matrix verb. Additionally, *ndò* must appear in the matrix clause rather than *kò*. This is illustrated in (82).

(82) *Nonlocal-subject focus*

Bruce₁ **ndò/*kò** Bòmá jírí-*(**kè**) [_{CP} ___₁ á ésé-mà]
 Bruce FOC/*FOC.SBJ Boma know-*(KE) her see-NFUT

‘Boma knows (that) Bruce saw her.’

[Bennett et al. 2012:297, ex. (18)]

The fact that the fronted embedded subject in (82) must be marked with *ndò* and cannot be marked with *kò* makes it pattern with fronted objects. This makes it clear that the choice between *ndò* and *kò* does not draw the distinction between subjects and nonsubjects per se, but between local subjects and everything else—the same distinction that conditions the appearance of *kè*. In other words, *kè* appears whenever the fronted element is accompanied by *ndò*, and *kè* and *ndò* are mutually exclusive with *kò*.

4.2. vP-phase account

Bennett (2009) and Bennett et al. (2012) argue that the distribution of *kè* provides evidence for vP phases (also see Van Urk 2016, 2020a,b). They propose that focus extraction of any element that is not located at the vP edge requires it to first move to [Spec,vP] in order to leave the vP phase. *Kè* is then analyzed as reflecting such intermediate movement. Such movement is required for nonsubjects and nonlocal subjects but not for local subjects, which are base-generated at the vP edge. Importantly, however, Bennett (2009) and Bennett et al. (2012) argue that *kè* is *not* located within the vP but within a higher head (which they dub “X⁰”) that is located between vP and TP. The reason is that movement of the vP does not move *kè* along, as would be expected if *kè* were part of the vP. The authors suggest that *kè* selects for a vP that bears a [+Focus] feature (which attracts an element to its edge). Thus, if v attracts a [+Focus] element to its edge, then the next-higher head is realized as *kè* as schematized in (83).¹⁹

¹⁹ Bennett (2009) and Bennett et al. (2012) assume subsequent movement of the vP to [Spec,TP] to ensure that *kè* ends up in sentence-final position (along the lines of Kayne 1994). For the sake of exposition, we do not represent this movement in (83). In our own analysis, we take the head that hosts *kè* to be head-final, so that no vP movement is necessary to derive the final position of *kè*.

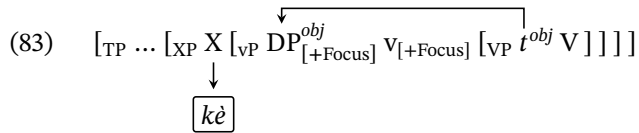

On Bennett’s (2009) and Bennett et al.’s (2012) analysis, the link between vP phasehood and *kè* is thus only indirect: *kè* is not a direct reflex of movement to [Spec,vP] or the feature that underlies it.

Next, in order to account for the distribution of *ndò* and *kò*, Bennett (2009) and Bennett et al. (2012) locate these elements in the left periphery. Concretely, they propose that the clausal spine contains one projection that licenses a subject (“SubjP”) and a higher FocusP projection. If any element other than the local subject is fronted, this element occupies [Spec,FocusP] while the local subject is located in [Spec,SubjP], as shown in (84). In this case, Focus⁰ is realized as *ndò*.

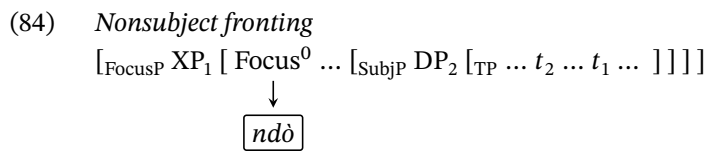

Building on work by Giorgi and Pianesi (1996), they then propose that if a local subject is focus-fronted, these two projections are combined into a joint {Focus–Subj} projection, whose specifier is occupied by a fronted local subject, as shown in (85). This {Focus–Subj} head is then realized as *kò*.

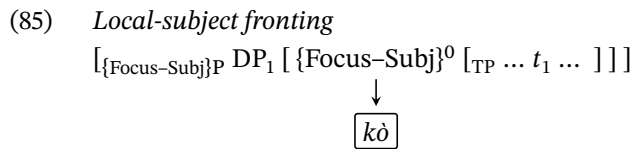

They furthermore assume that if a joint Focus–Subj projection is possible, it must be used, making *kò* obligatory with local-subject extraction.

Bennett’s (2009) and Bennett et al.’s (2012) analysis is insightful, and we will preserve several key aspects of it in our own account, but also faces a number of concerns, to which we now turn. First, while Bennett (2009) and Bennett et al. (2012) appeal to vP phasehood to derive the distinction between local subjects (which originate at the vP edge) and objects (which must move, hence triggering *kè*), it is not at all clear that this analysis handles adjuncts correctly. As shown in (80), adjunct fronting likewise triggers *kè*. On a vP phase account, this would require that *all* adjuncts are base-generated within the VP so that they must move to [Spec,vP] in order to be extracted to CP. Bennett (2009) and Bennett et al. (2012) do not provide independent support for the claim that all relevant adverbs originate VP-internally. The fact that even locative and temporal adverbs that generally have to be vP-external given their scopal behavior behave in this way and would hence need to be generated inside the VP casts serious doubts on this crucial part of the account. This is particularly pressing for adverbs that make reference to the utterance time like *òmò mò* ‘now’ in (80b).

To put this objection somewhat differently, vP phases derive a distinction between elements at the vP edge and VP-internal material. But empirically, the crucial split in Defaka is between local subjects on the one hand and everything else on the other. If only local subjects and objects are considered, these two line up. But once adjuncts are brought into the picture, the empirical

split between local subjects and everything else does not correlate (under standard views about the position of adjuncts) with the distinction between VP-internal and VP-external material that vP phases give rise to. We take this as an indication that it is not vP that underlies the split.

In addition, the vP-phase analysis faces a conceptual problem as well. As shown in section 4.1, the distribution of *kè* correlates with that of *ndò*, which marks fronted XPs other than local subjects. Despite the fact that the two markers appear under the same conditions, Bennett’s (2009) and Bennett et al.’s (2012) analysis treats them separately: *kè* is analyzed in terms of vP phases, while *ndò* is attributed to properties of higher functional projections. In light of the similarities in the distribution of *kè* and *ndò*, one might wonder whether it is not possible to analyze *kè* in terms of higher functional projections as well. Note that such a more unified analysis would also be consistent with Bennett’s (2009) and Bennett et al.’s (2012) observation that *kè* realizes a vP-external and, in fact, sentence-final head. In the next section, we will develop such an analysis. This analysis is based on DP intervention and as we will show not only links *kè* and *ndò* more directly, it also obviates the need for vP phases.

4.3. DP-intervention analysis

The analysis we develop preserves Bennett’s (2009) and Bennett et al.’s (2012) key idea that the distribution of *ndò* and *kò* is conditioned by whether the projection that hosts the subject and the Focus projection are conflated into a single projection or not. But we show that this line of analysis can be extended to *kè* once it is framed in terms of DP intervention instead of vP phasehood. Additional appeal to phases is then unnecessary. We follow Bennett’s (2009) and Bennett et al.’s (2012) that the subject raises to a specifier of a phrase higher than TP, which they dub “SubjP” (a term we adopt for convenience without making particular commitments to its exact nature). For this, we assume a simple CP > SubjP > TP > vP > VP clause structure, as before. C is responsible for focus-fronting an XP, and in line with our accounts of Indonesian and Dinka, C may only attract the closest DP. As a result, if a nonsubject is to be \bar{A} -extracted, it must first move to an outer specifier of SubjP in order to be attractable by C. We also follow Bennett (2009) and Bennett et al. (2012) in the assumption that if Subj and C would have the same element in their specifiers, they are conflated into a single {C–Subj} projection that comprises the features of both Subj and C.²⁰

Against this background, we propose that *ndò* and *kò* are the realization of C and that *kè* is the realization of Subj. Their precise specifications are given in (86). All three realize [*uFoc*] features, but they differ in the context of this [*uFoc*] feature.²¹ First, *ndò* in (86a) realizes [*uFoc*] on a C head

²⁰ We adopt the conflation aspect of Bennett’s (2009) and Bennett et al.’s (2012) account for two reasons. First, it allows for an easier comparison between the two approaches, demonstrating that it is possible to dispense with vP phases while leaving other aspects of their account intact. Second, the idea that certain heads can be conflated has been independently proposed for heads in the TP domain (Bobaljik 1995, Thráinsson 1996, Giorgi and Pianesi 1996, 1997, Bobaljik and Thráinsson 1998), in the CP domain (Bianchi 1999), across these two domains (Gallego 2017), and in the vP domain (Pykkänen 2002, 2008, Harley 2017). Additionally, Legate (2011, 2014), Martinović (2015, 2019), and Erlewine (2018) have argued that C and T can be conflated into a single head for Acehnese, Wolof and Toba Batak, respectively. Finally, Hsu (2016, 2021) develops a general theory of head bundling across a number of domains.

²¹ While nothing crucial hinges on this, we assume that the crucial movement-inducing feature in Defaka is [*uFoc*] rather than [*uδ*] (as we did for Indonesian). The reason is that in Defaka the distribution of the morphological reflex is more narrow: it appears if the moving element is “emphasized or pragmatically salient” (Bennett 2009:1), which leads Bennett et al. (2012:294) to associate it with focus movement only.

in the context of an overt specifier (that is, *ndò* is not triggered by an intermediate landing site). Second, *kò* in (86b) realizes [*uFoc*] on a conflated {C-Subj} head, also in the context of an overt specifier. Third, *kè* in (86c) realizes [*uFoc*] on a Subj head, the feature responsible for leapfrogging. The restriction of *ndò* and *kò* to heads with an overt specifier is to limit their appearance to the final landing site of the movement chain. We assume that vocabulary insertion follows chain reduction and hence that the information about whether a copy is overt or not is available to vocabulary insertion.

- (86) a. /*ndò*/ ↔ C_[*uFoc*] / [_{CP} XP ____
 b. /*kò*/ ↔ {C-Subj}_[*uFoc*] / [_{{C-Subj}P} XP ____
 c. /*kè*/ ↔ Subj_[*uFoc*]

The claim that *kè* realizes a structurally high head (higher than TP) is independently motivated by morphological considerations. As (79c) illustrates, *kè* is separated from the verb root by tense and negation. In line with the mirror principle (Baker 1985), this ordering indicates that *kè* realizes a head higher than T and Neg, all of which are head-final and hence realizes as suffixes.

As in our analyses of Dinka and Indonesian, we assume that C in Defaka may only attract the closest element, even in cases where an intervening element is not focused. Because fronting is associated with a focus interpretation in Defaka, we broadly adopt the analysis of Indonesian, according to which C bears a complex probe. Unlike Indonesian, however, intervention is not category-specific in Defaka. Fronting of PPs and adverbs requires *kè* and hence leapfrogging. We therefore propose the complex probe in (87).

- (87) C: [*uFoc+uX*]

Here, the feature [*uX*] is a “catch-all” feature that is not category-specific but can instead be matched by a variety of categories, including DPs, PPs, and adverbs. In this respect, it is similar to the attracting feature in V2 languages like Dinka or German, where a variety of elements may be used to satisfy the V2 requirement.²² In a way, then, (87) combines aspects of our analysis of Dinka and of

A reviewer points out that it is possible that *kè* is not restricted to focus fronting and provides the examples in (i). (ia) involves focus fronting of a PP (for reasons unclear to the reviewer and us, the P is dropped), along with *ndò* and *kè*, as expected. Interestingly, (ib) involves PP fronting without *ndò*. The reviewer suggests that (ib) might involve locative inversion. Notably, *kè* still appears on the verb. This might suggest that *kè* is not confined to focus fronting after all. This is in principle compatible with our analysis because the PP must still leapfrog over the subject in (ib) but it would suggest that Subj bears [*uδ*] instead of [*uFoc*]. In light of the uncertainty about how general the pattern in (ib) is, we restrict ourselves to the pattern as discussed by Bennett (2009) and Bennett et al. (2012) here, with *kè* arising with focus movement.

- (i) a. ányó bàà ndò Bò má ré ìbì-lèm-kè
 fire side FOC Boma re see-lem-KE
 'Boma is sleeping by the fire side'
 b. ányó bàà tè Bò má ré ìbì-lèm-kè
 fire side P Boma re see-lem-KE
 'Boma is sleeping by the fire side.'

²² [*uX*] in (87) could therefore be thought of as a maximally underspecified category feature. This conception raises the question why the SubjP does not intervene for Agree between C and a DP. A plausible explanation is that TP is too local

Indonesian. Recall from the analysis of Indonesian that complex probes like (87) cannot attract a fully-matching element over a partially-matching one (Erlewine 2018, Coon and Keine 2021, Coon et al. 2021). As a consequence of (87), C cannot attract a focused element over a nonfocused subject. This results in the need for leapfrogging in the by now familiar way.

Let us consider a number of specific configurations. We begin with local-object \bar{A} -movement, illustrated in (88). In this configuration, the object bears a [Foc] feature. After the subject A-moves to [Spec,SubjP], it intervenes between C and the focused object. The complex probe (87) can therefore not attract the object from its base position. Object extraction thus requires leapfrogging of the object to an outer [Spec,SubjP] above the subject, triggered by [u Foc] on Subj. C can then attract the object to [Spec,CP] because the object matches both [u X] and [u Foc]. Given the items in (86), the derivation in (88) results in Subj being realized as *kè* and C as *ndò*. To derive the sentence-final appearance of *kè*, we assume that Subj is head-final and linearly follows its complement. To aid readability here and throughout, we show Subj to the left of its complement in the bracket structures.

(88) *Local-object fronting*

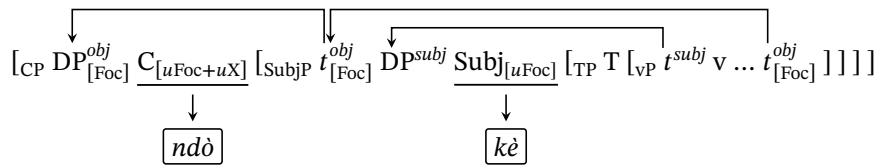

Next, consider \bar{A} -fronting of a local subject, schematized for an external argument in (89) but the mechanism is exactly the same for unaccusatives. Following the proposal in Bennett (2009) and Bennett et al. (2012), in this case C and Subj are conflated into a single {C-Subj} head that subsumes the featural content of both C and Subj. Movement of the focused subject to [Spec,{C-Subj}P] simultaneously satisfies T's EPP requirement and C's [u Foc+ u X].²³ In line with the items in (86), the {C-Subj} head is realized by *kò*.

(89) *Local-subject fronting*

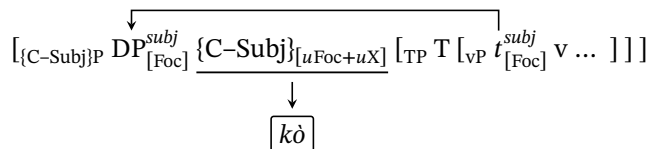

This account predicts that no *kè* arises with \bar{A} -movement of the sole argument of an unaccusative verb because no leapfrogging is necessary. As a reviewer informs us, this prediction is borne out.²⁴

for attraction by C (Abels 2003, 2012) and that elements that are too local are simply ignored for the operation of probes (Branan 2021).

²³ See also Van Urk (2015) for the general proposal that a single movement step may satisfy both A- and \bar{A} -features on a head.

²⁴ The reviewer also notes that for some speakers, focus movement with unaccusative verbs marginally allows for *ndò* (rather than the expected *kò*) “under the right circumstances”. What these circumstances are is unclear, and so we have no new insights to offer. Notably, however, *kè* is still impossible even if the fronted element is marked with *ndò* in these cases. This is predicted by our account.

Third, let us consider a configuration in which an adjunct to SubjP is \bar{A} -extracted, such as the temporal adverb in (80). The structure is schematized in (90). As we take all adjuncts to be base-generated below SubjP (as adjuncts are generally base-generated in non-peripheral positions), the temporal adverb is base-generated at TP in (90). [$uFoc$] on Subj attracts the adverb to an outer [Spec,SubjP], leading to *kè*, as above. The adverb then undergoes focus movement to [Spec,CP]. As a result, Subj is realized as *kè*, and C is realized as *ndò*.

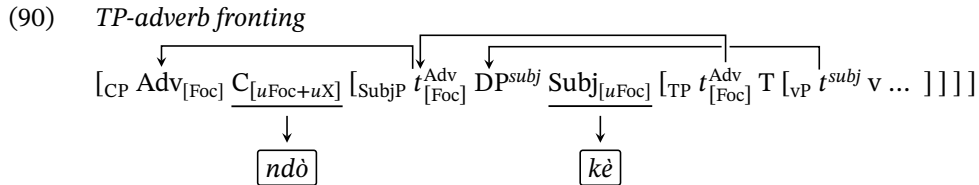

Next, let us turn to long-distance movement of an object. Such movement results in *kè* in every clause that is crossed by movement and in *ndò* in the clause that hosts the criterial position of the moved DP. The relevant structure is given in (91). Because CP is a phase, extraction out of the embedded clause must proceed through [Spec,CP], which we assume is triggered by a noncriterial counterpart of (87) on the intermediate C.²⁵ As in the previous cases, the [Foc]-bearing object is attracted by the embedded Subj, leading to leapfrogging over the subject. After subsequent movement to the embedded [Spec,CP], the object is then attracted by the matrix Subj's [$uFoc$], from where it is then attractable by the matrix C. Because both clauses contain a Subj with a checked [$uFoc$] feature, *kè* appears in both. By contrast, *ndò* appears only in the matrix clause because [$uFoc$] on the intermediate C is not in the context of an overt element in [Spec,CP], and insertion of *ndò* is therefore not licensed.²⁶

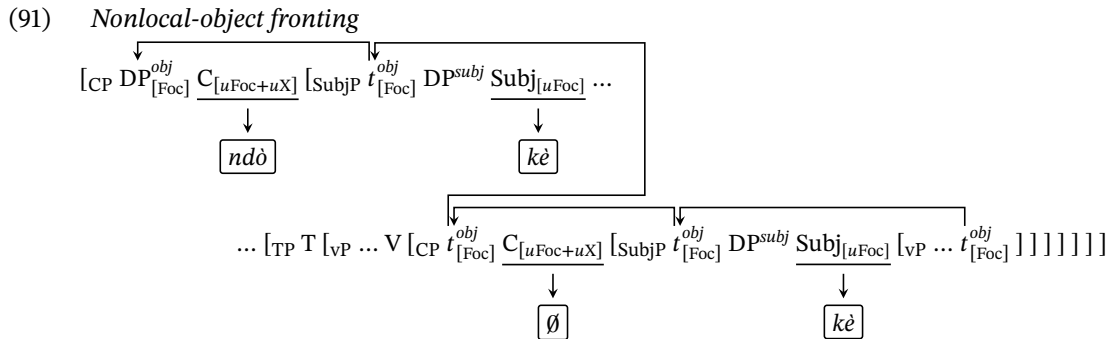

²⁵ Other implementations of obligatory movement through the CP phase edge are of course possible so long as these are restricted to the highest element in the clause, thus requiring leapfrogging over the embedded external argument.

²⁶ Of course, nothing prevents the embedded C from bearing a *criterial* [$uFoc$] feature. In this case, \bar{A} -movement to the embedded [Spec,CP] is terminal and not followed by movement into the matrix clause (Rizzi 2006, 2010, 2015). The result is embedded focus fronting that is accompanied by an embedded *ndò* and *kè*. This is correct, as (i) shows (the matrix *kò* in (i) is the result of local fronting of the matrix subject *Bòmá*, an instance of the derivation in (89)).

(i) Bòmá 'kó fàà-mà-(*kè) [CP ándù_i ndò iní ____i été-kè]
 Boma FOC.SBJ say-NFUT-(*KE) canoe FOC they have-KE
 'Boma said it's a canoe that they have.'

[Bennett et al. 2012:297, ex. (22)]

Finally, this account also handles nonlocal-subject extraction (see (82) for an example). In this case, the fronted embedded subject bears *ndò*, and *kè* appears on the matrix verb but not the embedded verb. The corresponding structure is given in (92). Due to CP phasehood, the embedded subject ($DP_{[Foc]}^{subj-2}$ in (92)) must first move to the edge of the embedded clause. Just as in (89), the embedded CP and SubjP are conflated into a single projection, which attracts the external argument to its specifier. From this position, the embedded subject must then move to an outer matrix [Spec,SubjP] in order to be attractable by the matrix C (due to intervention by the matrix subject DP^{subj-1}). It hence agrees with Subj's [uFoc], followed by Agree with matrix C. In line with (86), the matrix C is realized as *ndò*, the matrix Subj as *kè*, and the embedded {C-Subj} as \emptyset because it is not in the context of an overt specifier.

(92) *Nonlocal-subject fronting*

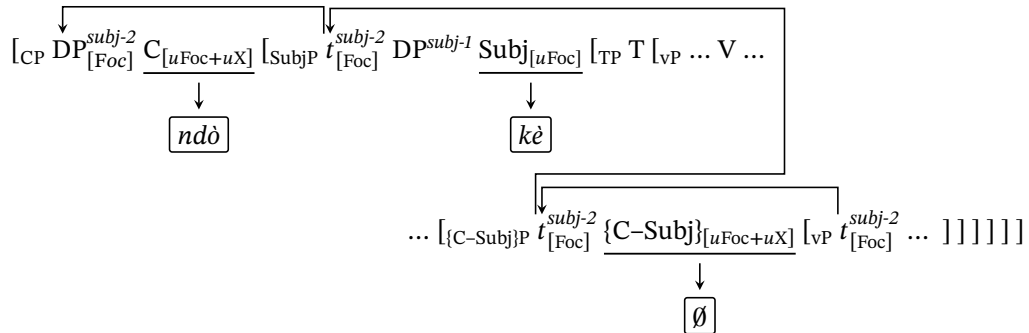

In sum, this alternative account of the Defaka facts derives the pertinent facts in section 4.1, but without appeal to vP phasehood or successive-cyclic movement through [Spec,vP]. The move away from vP phases resolves a number of problems that a vP-phase analysis faces. First, it offers an account of why \bar{A} -fronting of temporal and locative adverbs requires *kè* without needing to stipulate that such adverbs must be base-generated at VP. As such, unlike the vP-phase account, our account derives the crucial empirical split between local-subject movement and movement of everything else. If the local subject is \bar{A} -moved, SubjP and CP conflate, bleeding both *kè* and *ndò*. If any other element is focused, it must first move to an outer [Spec,SubjP], leading to *kè*. Second, our account establishes a closer connection between *ndò* and *kè*. As discussed in section 4.2, because *ndò* is clearly located in a structurally high position, it cannot be analyzed in terms of vP phases. Bennett's (2009) and Bennett et al.'s (2012) phase account therefore handles *kè* and *ndò* in an unrelated manner, despite the fact that their distribution is largely conditioned by the same factor (the presence of \bar{A} -movement of an element other than the local subject). By locating both effects higher than vP, our analysis ties them together more closely. *Ndò* appears when an element other than the local subject is attracted to C, and these are the elements that first undergo leapfrogging over the local subject, yielding *kè*.

Finally, the order of morphemes in Defaka provides evidence that the location of the morphological reflex *kè*—and hence the landing site of clause-internal successive cyclicity—may be higher than TP. This complements our findings for Indonesian and Dinka. Taken together, clause-internal successive cyclicity does not appear to target a single fixed position but instead either vP (Indonesian), TP (Dinka), or an even higher SubjP (Defaka). Furthermore, we found that this position

correlates with the position of the subject in these languages: [Spec,vP] in Indonesian, [Spec,TP] in Dinka, and [Spec,SubjP] in Defaka. Both conclusions do not follow from a vP-phase account, but they receive a principled explanation on a DP-intervention account. Because leapfrogging must move the object over the subject to make it attractable by C, it follows that the height of the leapfrogging step must correlate with the position of the subject DP. We thus take the crosslinguistic variability of the intermediate landing site as additional evidence for a DP-intervention account of these effects. As already noted at the end of section 3, while some existing accounts assume that phasehood may be variable (e.g., Bošković 2014, Harwood 2015), such accounts nonetheless locate the clause-medial phase below T. They therefore do not lend themselves to the more radical variability of the location of the intermediate landing site across the three case studies here.

5. Taking stock: Absolute vs. relative locality and the CP–vP distinction

We began this paper by laying out two possible accounts of successive cyclicity along a movement path. The traditional account attributes intermediate landing sites to locality domains, in particular phases: the moving element must move through the phase edge in order to remain accessible for subsequent operations. The alternative account, building on recent proposals about the behavior of \bar{A} -probes, attributes these intermediate landing sites to DP-intervention: C can only attract the closest DP goal and so a nonsubject DP must first leapfrog over the subject in order to be attractable.

- (93) a. *Domain/phase-based approach:*
 Obligatory successive-cyclic movement through a clause-internal position is the result of a clause-internal phase.
- b. *DP-intervention approach:*
 Obligatory successive-cyclic movement through a clause-internal position is the result of leapfrogging around an intervening DP.

We considered three case studies in which morphological reflexes of movement indicate clause-internal successive cyclicity, and we compared the two approaches in (93) for these case studies. While existing accounts of these three patterns all pursue a domain/phase-based analysis (93a), we have argued that these patterns are in fact better understood as cases of DP-intervention (93b). Across these case studies, our arguments for a DP-intervention account were the following: First, the position of the intermediate landing site correlates with the position of the subject across the three languages (vP in Indonesian, TP in Dinka, SubjP in Defaka). Second, the requirement for successive cyclicity is selective: in Indonesian, PPs and adverbs do not trigger the reflex even if they cross vP; in Dinka, PP adjuncts do not trigger the empty-edge effect. Third, in Defaka, adjuncts that are arguably VP-external (and hence should not have to pass through [Spec,vP]) nonetheless trigger the effect. Fourth, in Indonesian, movement of an external argument is not restricted in active clauses (where the external argument is the highest DP), but movement of the external argument is restricted in passives (where the external argument is *not* the highest DP in the vP). Assuming that the external argument is generated in [Spec,vP] in both cases, this asymmetry is unexpected on a vP-phase account, further compounded by the behavior of unaccusative predicates

in Indonesian. Fifth, DP arguments of unaccusative verbs do not trigger the reflex in any of the three languages. This must be stipulated on a phase-based account (e.g., unaccusative vP happens to not have phasal properties, see Chomsky 2000, 2001 and fn. 11) but it follows immediately on a DP-intervention account. Sixth, unaccusatives in Dinka impose similar conflicting requirements for the phase status of the corresponding vP.

We conclude, therefore, that the morphological reflexes of successive-cyclic movement in these three languages are better analyzed in term of DP intervention and leapfrogging. In principle, this conclusion is compatible with the existence of vP phases. Because all of the empirical generalizations follow from DP intervention, they do not provide direct empirical evidence either for or against vP phases. Thus, our analysis could in principle be combined with vP phases, but in this case vP phases would have no empirical effect even in these languages. With the empirical need for vP phases having thus disappeared, the question now arises whether we can adopt a stronger conclusion—that (93b) is not just supported but in fact replaces the need for (93a) and hence clause-medial phases altogether. While we cannot investigate this question in detail here, in what follows we will offer several arguments that this stronger conclusion might indeed be warranted.

5.1. Optional vs. obligatory successive-cyclic movement

In the discussion so far, we focused on cases of successive cyclic movement in the middle field that have clear morphological reflexes. There are, of course, arguments for clause-medial phases—in particular vP phases—based on other empirical patterns. This raises the question whether these other patterns provide evidence for clause-medial phases.

To illustrate, one traditional argument for the presence of an intermediate landing site in a clause-internal position (typically taken to be [Spec,vP]) is based on reconstruction and due to Fox (1999), Legate (2003), and Sauerland (2003) (also see Agüero-Bautista 2001). The argument is based on configurations like (94). In this example, the \bar{A} -moved DP contains (i) the pronoun *he*, which is bound by *every student* and (ii) the R-expression *Ms. Brown*, which is coindexed with the pronoun *her*. Fox (1999) reasons that the moved constituent cannot be interpreted in either its base position or its surface position. This is because in the base position, the R-expression *Ms. Brown* is c-commanded by *her*, which would violate Condition C. In the surface position, *he* is not c-commanded by *every student*, which is incompatible with the bound reading of the pronouns. Fox concludes that the moved DP must be interpreted in an intermediate position that is located lower than *he* (to allow binding) but higher than *Ms. Brown* (to escape Condition C). Fox identifies this position as [Spec,vP]. (94) then shows that it is possible for an \bar{A} -moved element to create an intermediate landing site at vP.

- (94) [Which of the books that **he**₁ asked **Ms. Brown**₂ for] did **every student**₁ ___ get from
her₂ * ? [Fox 1999:174, ex. (40a)]

As it turns out, such data do not bear on the choice between the two approaches in (93) because they can be accounted for without appeal to either phases or DP intervention. The reason is that the availability of the relevant reading in (94) provides evidence that it is *possible* for the moved element to reconstruct into an intermediate position. This does not entail that the moving element

must pass through a clause-internal intermediate position, only that it *may* do so. Thus, while data like (94) are standardly taken as support for the presence of a clause-internal phase, they in fact underdetermine the analysis. A viable alternative is to treat the intermediate landing site as simply the result of a different movement type that applies optionally. For example, Grohmann (1997), Wiltschko (1997), Fanselow (2004), and others provide evidence that *wh*-movement in German may optionally be preceded by a scrambling/QR step (see also Takahashi 1993 for Japanese). For English, Kotek (2014, 2019) and Poole (2017) argue that *wh*-movement may be preceded by a covert scrambling step, which also instantiates QR and which is unrelated to phasehood.²⁷

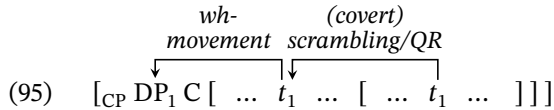

As long as one movement type may apply to the output of another, the derivation in (95) is allowed regardless of whether there is a clause-internal phase. The intermediate landing site that is implicated in the arguments from reconstruction can then be analyzed as the landing site of the scrambling step in (95), without appeal to phases. While the intermediate movement step in (95) is then optional, the fact that it is possible is sufficient to account for (94). One implication of this alternative analysis is that such intermediate landing sites should not be limited to one specific position like [Spec,vP]. This seems correct. Fox (1999:175n32) notes that it is possible to use the reconstruction evidence to diagnose an intermediate landing site in every maximal projection. This seems to us to be an argument against a phase-based account of the reconstruction facts, at least unless one treats all phrases as phases, in which case the phase–nonphase distinction collapses. By contrast, if the intermediate landing site—rather than being tied to phasehood—is created by optional QR with a flexible landing site, as we have proposed, then the variability in the location into which reconstruction takes place receives an immediate explanation. We conclude from these considerations that (94) does not provide conclusive evidence for the existence of a clause-medial phase and does not bear on the two approaches in (93). More generally, arguments that merely establish the *optional* presence of an intermediate landing site do not bear on the choice between the hypotheses in (93).

Other purported arguments for vP phases are subject to the same objection, for example arguments based on parasitic gaps (Nissenbaum 2000:48–53, Legate 2003:510–511, Abels 2012:43–47). These arguments are based on Nissenbaum’s (2000) account of parasitic gaps, which requires an intermediate landing site in [Spec,vP]. On this account, the possibility of parasitic gaps again establishes that it is *possible* for an \bar{A} -moved object to pass through an intermediate landing site, but it does not establish that such a landing site is *obligatory*.

A third argument of this type is based on quantifier float in varieties of West Ulster English (McCloskey 2000, Henry 2012). Many of these varieties allow floating of *all* in a greater set of environments than standard English, including at the vP edge, as Henry (2012) shows. (96) provides an example from East Derry English.

²⁷ Legate (2003) argues based on Antecedent-Contained Deletion that QR may target both agentive and nonagentive vP in English. Legate concludes from this that both types of vP are a phases. But like the argument from reconstruction, this argument only demonstrates that vPs provide a possible landing site for QR, not an obligatory one, and as such it does not require vP to be phase, as far as we can tell.

(96) What₁ did he [_{vP} **all** do ___₁ in Derry]? [Henry 2012:31, ex. (52)]

At least on a stranding analysis of quantifier float (Sportiche 1988, Bošković 2004; though see Bobaljik 2003 for critical discussion), (96) demonstrates that it is possible for the \bar{A} -moved element to move through a [Spec,vP] and strand *all* there. As before, because quantifier float is optional, these facts are equally compatible with the alternative analysis in (95).

We conclude, therefore, that data that only establish the optional presence of an intermediate landing site are too weak to bear on the choice in (93). Adjudicating between the two approaches in (93) requires empirical patterns that indicate the obligatory presence of an intermediate landing site, such as the cases discussed in section 2–4.

5.2. Locality asymmetries between CPs and vPs

Another way of evaluating the two hypothesis to account for vP-based locality in (93) is to see how other effects of phase-based locality, most notably CP-based locality, compare to vP-based locality. If similar locality effects can be attested around vPs as around CPs, that would call for a unified treatment of the these effects, arguably in terms of phasality (given that CP-based phasality is hardly disputed). On the other hand, if various locality effects that apply to CPs do not hold for vPs, that would argue against such a unified approach.

There is a growing body of evidence that indicates fundamental differences in the locality effects of vP and CPs. In particular, CPs exhibit certain locality effects that vPs (including transitive vPs) systematically lack. Assuming that these locality effects are the result of CP phasehood, these asymmetries provide arguments that vPs and other clause-medial projections are *not* phases. This then open up the possibility that *all* locality effects associated with clause-internal projections are the result of DP intervention.

Locality of φ -agreement: The first difference between CPs and vP concerns the locality of φ -agreement (Keine 2020b:272–278). This asymmetry is based on a crosslinguistic generalization that Polinsky (2003) and Bobaljik (2008) identify for long-distance agreement (LDA). According to this generalization, LDA may target the edge of an embedded CP clause but not material that is more deeply embedded (see Bruening 2001, Polinsky and Potsdam 2001, Branigan and MacKenzie 2002). This is, of course, precisely the locality profile we would expect if CP is a phase. Once the matrix φ -probe enters the structure, only the edge of the embedded clause is accessible, imposing a principled limit on the distance of LDA (see (97)). Keine (2020b) reasons that if vP is a phase, we expect it to likewise limit LDA to its edge. Based on evidence from Hindi-Urdu, Keine (2020b) argues that this is not the case. Instead, we find φ -agreement that crosses an arbitrary number of vPs (but still cannot cross a CP), as schematized in (98).

(97) [T_[u φ] ... [CP (DP_[φ]) [TP ... (DP_[φ]) ...]]]

(98) [T_[u φ] ... [vP ... [vP ... [vP ... DP_[φ] ...]]]]

An example of (98) is provided in (99). LDA is possible here (the slight degradation is due to the center embedding). (99) uses an idiom as in this idiom the embedded object and agreement controller *Pratap-kii khuub marammat* ‘Pratap’s many repairs’ resists movement. Keine (2020b) furthermore argues that the agreement is established between the matrix T and the embedded object directly rather than mediated via the intervening verbs (also see Bhatt 2005) and that the embedded clauses contain vP projections. Because the agreement controller independently resists movement on the idiomatic interpretation, LDA must cross these vP projections.

- (99) ?Ram-ne [vP [vP Pratap-kii khuub **marammat** kar-nii] shuruu kar-nii]
 Ram-ERG Pratap-GEN lot repair.F.SG do-INF.F.SG start do-INF.F.SG
 caah-ii.
 want-PFV.F.SG
 ‘Ram wanted to start giving Pratap a good beating.’ (*lit.* ‘Ram wanted to start doing Pratap’s many repairs.’) [Keine 2020b:277, ex. (437)]

The observation that vPs are in principle transparent to φ -agreement across them whereas CPs categorically are not indicates a clear asymmetry between CPs and vP in terms of their locality effects. If phases constrain φ -agreement, the locality effect in (97) follows from CP phases but then (98) indicates that vP is *not* a phase. If phases do not constrain φ -agreement (e.g., Bošković 2007), then the locality effect in (97) requires a different explanation. As a reviewer notes, a possible account is that C bears φ -features that intervene for agreement across C whereas v does not contain φ -features. Notably, phasehood then plays no role in the account of the agreement pattern at all, and the analysis is compatible with the view that there are no clause-medial phases at all.

In sum, depending on the interaction between φ -agreement and phases, the locality asymmetry in (97)/(98) either provides evidence against clause-medial phases, or is at least consistent with the absence of such phases.

Locality of phase-bounded movement: Grano and Lasnik (2018) propose that certain movements cannot proceed successive-cyclically but must proceed in one-fell-swoop (for example gapping, QR, *too/enough*-movement). Such movements are therefore phasebounded, and they ordinarily cannot leave a CP (in some cases they can, and Grano and Lasnik 2018 propose that in these configurations CP does not act as a phase). What matters for our concerns here is that such movements are not obstructed by vPs at all. Grano and Lasnik (2018:486–490) conclude that the most principled theory of this asymmetry is one where CP is a phase but vP is not.

Locality of negative concord and NPI licensing: Other dependencies that are subject to syntactic locality exhibit an analogous pattern: they may not cross a CP boundary but they may cross a vP. Examples include negative concord (Zeijlstra 2004, 2012) and licensing of strong NPIs (see Giannakidou and Zeijlstra 2017 and the references therein).

- (100) a. Gianni **non** ha [_{vP} telefonato **a nessuno**].
 Gianni NEG has called to nobody
 ‘Gianni didn’t call anybody.’ [Zeijlstra 2004:130, ex. (50a)]
- b. *Gianni **non** ha detto [_{CP} che ha telefonato **a nessuno**].
 Gianni NEG has said that has called to nobody
 ‘Gianni didn’t say that he called anybody.’ [Zeijlstra 2012:520, ex. (53)]
- (101) a. Mary **didn’t** [_{vP} talk to **any** student **at all**].
- b. *Mary **didn’t** say [_{CP} that they talked to **any** student **at all**].

Locality of dependent-case assignment: Poole (2022) argues that dependent-case assignment may not cross a CP, but that it may cross a vP. Poole (2022:42) notes that one way in which this asymmetry can be derived is if CP is a phase, but vP is not.

Intermediate gaps in sentence processing: Gibson and Warren (2004) argue that intermediate landing sites created by successive cyclicity facilitate filler retrieval in online sentence processing. Keine (2020a) compares the effect of crossing a CP and of crossing a vP on such facilitation. He finds that while crossing a CP facilitates filler retrieval, crossing a vP does not. He then suggests that this asymmetry receives a principled explanation if CP is a phase (hence requiring an intermediate landing site) but vP is not.

All of these patterns involve the same asymmetry between CP and vP: a dependency that is blocked across CPs is not similarly affected by an intervening vP. The locality effect of CPs for these dependencies bears the typical properties of phase locality: movement out of CP must proceed through the edge, and in-situ dependencies like agreement are restricted to the CP edge and cannot access lower material. While the discussion above is necessarily brief, the conspicuous absence of analogous effects at vPs and other clause-medial projections provides reason to believe that these are not phases. In conjunction with the conclusions argued for in sections 2–4, a stronger conclusion now suggests itself: not only are some apparent effects of clause-medial phasehood the result of DP intervention (that is, (93b) is feasible); but DP intervention might replace appeal to clause-medial phases entirely. This move provides an immediate explanation of the various asymmetries asymmetries just discussed, and it is fully in line with our reanalysis of the morphological reflexes of clause-internal successive cyclicity. As mentioned in section 5.1, it is also compatible with evidence for optional intermediate landing sites.

Overall, it seems that it is not just the case that some clause-medial successive-cyclicity effects are the result of DP intervention rather than phasehood, but that a stronger conclusion is potentially warranted—that there are no clause-medial phases at all and successive cyclicity in this domain is exclusively the result of DP intervention and the need for leapfrogging. Of course, a full evaluation of this stronger hypothesis requires careful scrutiny of remaining arguments for clause-medial phases. Space limitations prevent us from pursuing this here but we would like to mention some relevant issues. One argument that we have not engaged with here is presented by Manetta (2010, 2011) on the basis of wh-scope marking in Hindi. Without going into the details of the argument or

Manetta’s analysis, we point the reader to Dayal (2017) for a reply and to Dayal (1994, 1996) and Lahiri (2002) for an alternative account of these constructions that does not involve vP phases. Another important argument for vP phases comes from Abels’s (2003, 2012) stranding generalization, which holds that complements of phase heads may not be moved. Abels shows that VP may not be moved if it is embedded under a vP, as predicted if vP is a phase. If vP is not a phase, this argument is in need of reanalysis, which we leave for future work. Other arguments for clause-medial phases are based on empirical patterns other than successive cyclicity. For example, Legate (2003), Kratzer and Selkirk (2007), Bošković (2016), and others argue that phases have prosodic reflexes as well and that vPs exhibit such reflexes. Bošković (2014) proposes that phases constrain ellipsis and consequently that the possibility of clause-internal ellipsis provides evidence for clause-medial phasehood. To what extent these arguments can be reconciled with the absence of clause-medial phases remains to be seen. It is worth noting that these arguments are based on clause-medial domains being the domain of application for prosodic and ellipsis processes, not locality domains for syntactic operations. This might suggest a possible avenue of reconciling these arguments with our conclusions here, a suggestion which we leave for future work as well.

In closing, we would like to briefly discuss our more general conclusion in light of Müller’s (2004, 2011) observation that there is an inherent tension between absolute locality domains like phases and relative notions of locality like minimality or intervention. Müller notes that intervention presupposes search space: such constraints have an effect only if the search space contains at least two elements that have the relevant property (so that one can intervene for movement of the other). By contrast, absolute locality domains like phases have the effect of limiting search space. Müller (2004, 2011) proposes that intervention-based locality constraints ought to be dispensed with in favor of absolute locality constraints like phases. While we have maintained the phase status of CP, our results point in the opposite direction—weakening the overall role of phasehood by decreasing the number of phase heads, and placing greater emphasis on intervention in the account of successive cyclicity.

Abbreviations used in glosses

ACC	accusative	LOC	locative	PFV	perfective
APPL	applicative	NEG	negation	PL	plural
ERG	ergative	NFUT	nonfuture	P	preposition
FOC	focus	NF	nonfinite	QUANT	quantifier
FUT	future	NOM	nominative	Q	questions particle
F	feminine	NSV	nonsubject voice	SBJ	subject
GEN	genitive	OBLV	oblique voice	SG	singular
HAB	habitual	OV	object voice	SV	subject voice
INF	infinitive	PAST	past tense	TR	transitive

Acknowledgements

For insightful discussions, comments, and feedback, we thank three anonymous *NLLT* reviewers, our editor Julie Legate, Mitcho Erlewine, Omer Preminger, Coppe van Urk, the audience at the Tel Aviv University Linguistics Colloquium, and the reviewers and audience at GLOW 43. Many

thanks also to Hooi-Ling Soh and Mitcho Erlewine for help with the Indonesian data, and to Coppe van Urk for help with the Dinka data.

References

- Abels, Klaus. 2003. Successive cyclicity, anti-locality, and adposition stranding. Ph.D. dissertation, University of Connecticut, Storrs, CT.
- Abels, Klaus. 2012. *Phases: An Essay on Cyclicity in Syntax*. Berlin: de Gruyter.
- Agüero-Bautista, Calixto. 2001. Cyclicity and the scope of wh-phrases. Ph.D. dissertation, MIT, Cambridge, MA.
- Aldridge, Edith. 2004. Ergativity and word order in Austronesian languages. Ph.D. dissertation, Cornell University, Ithaca, NY.
- Aldridge, Edith. 2008a. Generative approaches to ergativity. *Language and Linguistics Compass* 2/5: 966–995.
- Aldridge, Edith. 2008b. Phase-based account of extraction in Indonesian. *Lingua* 118: 1440–1469.
- Andersen, Torben. 2002. Case inflection and nominal head marking in Dinka. *Journal of African Languages and Linguistics* 23: 1–30.
- Andersen, Torben. 2007. Auxiliary verbs in Dinka. *Studies in Language* 31: 89–116.
- Arka, I Wayan and Christopher Manning. 1998. Voice and grammatical relations in Indonesian: A new perspective. In: *Proceedings of the LFG98 Conference*, ed. by Miriam Butt and Tracy Holloway King, Stanford, CA: CSLI, accessible at: <http://web.stanford.edu/group/cslipublications/cslipublications/LFG/3/lfg98arkamanning.pdf>.
- Baier, Nico. 2018. Anti-agreement. Ph.D. dissertation, University of California, Berkeley.
- Baker, Mark. 1985. The Mirror Principle and morphosyntactic explanation. *Linguistic Inquiry* 16: 373–415.
- Belletti, Adriana. 2017. (Past) participle agreement. In: *The Wiley Blackwell Companion to Syntax, 2nd edition, Vol. V*, ed. by Martin Everaert and Henk van Riemsdijk, Hoboken, NJ: Wiley, pp. 2972–3000.
- Bennett, Wm. G.. 2009. Two subject asymmetries in Defaka focus extraction, Qualifying Paper, Rutgers University, accessible at: <https://sites.google.com/site/wmgbennett/papers/Bennett%202009%20-%20Two%20subject%20asymmetries%20in%20Defaka%20focus%20extraction.pdf?attredirects=0&d=1>.
- Bennett, Wm. G., Akinbiyi Akinlabi and Bruce Connell. 2012. Two subject asymmetries in Defaka focus constructions. In: *Proceedings of the 29th West Coast Conference on Formal Linguistics (WCCFL 29)*, ed. by Jaehoon Choi, E. Alan Hogue, Jeffrey Punske, Deniz Tat, Jessamyn Schertz and Alex Trueman, Somerville, MA: Cascadilla Press, pp. 294–302.
- Bhatt, Rajesh. 2005. Long distance agreement in Hindi-Urdu. *Natural Language and Linguistic Theory* 23: 757–807.
- Bianchi, Valentina. 1999. *Consequences of Antisymmetry: Headed Relative Clauses*. Berlin: de Gruyter.
- Bjorkman, Bronwyn and Hedde Zeijlstra. 2019. Checking up on (φ -)Agree. *Linguistic Inquiry* 50: 527–569.

- Bobaljik, Jonathan. 1995. Morphosyntax: The syntax of verbal inflection. Ph.D. dissertation, MIT, Cambridge, MA.
- Bobaljik, Jonathan. 2003. Floating quantifiers: Handle with care. In: *The Second GLOT International State-of-the-Article Book*, ed. by Lisa Cheng and Rint Sybesma, Berlin: Mouton de Gruyter, pp. 107–148.
- Bobaljik, Jonathan. 2008. Where's Phi? Agreement as a postsyntactic operation. In: *Phi Theory: Phi-Features Across Interfaces and Modules*, ed. by Daniel Harbour, David Adger and Susana Béjar, Oxford: Oxford University Press, pp. 295–328.
- Bobaljik, Jonathan and Höskuldur Thráinsson. 1998. Two heads aren't always better than one. *Syntax* 1: 37–71.
- Boeckx, Cedric. 2003. *Islands and Chains: Resumption as Stranding*. Amsterdam: John Benjamins.
- Boeckx, Cedric and Kleanthes Grohmann. 2007. Putting phases in perspective. *Syntax* 10: 204–222.
- Bošković, Željko. 2002. A-movement and the EPP. *Syntax* 5: 167–218.
- Bošković, Željko. 2004. Be careful where you float your quantifiers. *Natural Language and Linguistic Theory* 22: 681–742.
- Bošković, Željko. 2005. On the locality of left branch extraction and the structure of NP. *Studia Linguistica* 59: 1–45.
- Bošković, Željko. 2007. Agree, phases, and intervention effects. *Linguistic Analysis* 33: 54–96.
- Bošković, Željko. 2014. Now I'm a phase, now I'm not a phase: On the variability of phases with extraction and ellipsis. *Linguistic Inquiry* 45: 27–89.
- Bošković, Željko. 2016. What is sent to spell-out is phases, not phasal complements. *Linguistica* 56: 25–66.
- Branan, Kenyon. 2021. Locality and anti-locality: The logic of conflicting requirements, to appear in *Linguistic Inquiry*.
- Branan, Kenyon and Michael Yoshitaka Erlewine. 2021. Ā-probing for the closest DP, to appear in *Linguistic Inquiry*.
- Branigan, Phil and Marguerita MacKenzie. 2002. Altruism, Ā-movement and object agreement in Innu-aimûn. *Linguistic Inquiry* 33: 385–407.
- Bruening, Benjamin. 2001. Syntax at the edge: Cross-clausal phenomena and the syntax of Passamaquoddy. Ph.D. dissertation, MIT, Cambridge, MA.
- Bruening, Benjamin. 2004. Two types of wh-scope marking in Passamaquoddy. *Natural Language and Linguistic Theory* 22: 229–305.
- Chomsky, Noam. 1973. Conditions on transformations. In: *A Festschrift for Morris Halle*, ed. by Stephen Anderson and Paul Kiparsky, New York, NY: Academic Press, pp. 232–286.
- Chomsky, Noam. 1977. On wh-movement. In: *Formal Syntax*, ed. by Peter Culicover, Thomas Wasow and Adrian Akmajian, New York: Academic Press, pp. 71–132.
- Chomsky, Noam. 1981. *Lectures on Government and Binding*. Dordrecht: Foris.
- Chomsky, Noam. 1986. *Barriers*. Cambridge, MA: MIT Press.
- Chomsky, Noam. 2000. Minimalist inquiries: The framework. In: *Step by Step: Essays on Minimalist Syntax in Honor of Howard Lasnik*, ed. by Roger Martin, David Michaels and Juan Uriagereka, Cambridge, MA: MIT Press, pp. 89–155.

- Chomsky, Noam. 2001. Derivation by phase. In: *Ken Hale: A Life in Language*, ed. by Michael Kenstowicz, Cambridge, MA: MIT Press, pp. 1–52.
- Chomsky, Noam. 2008. On phases. In: *Foundational Issues in Linguistic Theory: Essays in Honor of Jean-Roger Vergnaud*, ed. by Robert Freidin, Carlos Otero and Maria Luisa Zubizarreta, Cambridge, MA: MIT Press, pp. 89–155.
- Cole, Peter and Gabriella Hermon. 1998. The typology of *wh*-movement. *Wh*-questions in Malay. *Syntax* 1: 221–258.
- Cole, Peter, Gabriella Hermon and Yanti. 2008. Voice in Malay/Indonesian. *Lingua* 118: 1500–1553.
- Coon, Jessica, Nico Baier and Theodore Levin. 2021. Mayan Agent Focus and the Ergative Extraction Constraint: Facts and fictions revisited. *Language* 97: 269–332.
- Coon, Jessica and Stefan Keine. 2021. Feature gluttony. *Linguistic Inquiry* 52: 655–710.
- Csirmaz, Aniko. 2005. Semantics and phonology in syntax. Ph.D. dissertation, MIT, Cambridge, MA.
- Dayal, Veneeta. 1996. *Locality in Wh-Quantification: Questions and Relative Clauses in Hindi*. Dordrecht: Kluwer.
- Dayal, Veneeta. 2017. Does Hindi-Urdu have feature-driven *wh*-movement to Spec,vP? *Linguistic Inquiry* 48: 159–172.
- Dayal, Veneeta Srivastav. 1994. Scope marking as indirect *wh*-dependency. *Natural Language Semantics* 2: 137–170.
- Den Dikken, Marcel. 2007. Phase extension: Contours of a theory of the role of head movement in phrasal extraction. *Theoretical Linguistics* 33: 1–41.
- Den Dikken, Marcel. 2017. Overtly marked *wh*-paths. In: *The Wiley Blackwell Companion to Syntax: Second Edition, Vol. IV*, ed. by Martin Everaert and Henk van Riemsdijk, Hoboken, NJ: Wiley, pp. 2844–2884.
- Epstein, Samuel and T. Daniel Seely. 2002. Rule applications as cycles in a level-free syntax. In: *Derivation and Explanation in the Minimalist Program*, ed. by Samuel Epstein and T. Daniel Seely, Oxford: Blackwell, pp. 65–89.
- Erlewine, Michael Yoshitaka. 2016. Review of *Minimalist Interfaces: Evidence from Indonesian and Javanese* by Yosuke Sato. *Oceanic Linguistics* 55: 298–306.
- Erlewine, Michael Yoshitaka. 2018. Extraction and licensing in Toba Batak. *Language* 94: 662–697.
- Fanselow, Gisbert. 2004. The MLC and derivational economy. In: *Minimality Effects in Syntax*, ed. by Arthur Stepanov, Gisbert Fanselow and Ralf Vogel, Berlin: de Gruyter, pp. 73–123.
- Fortin, Catherine. 2006. Reconciling *meng*- and NP movement in Indonesian. In: *Proceedings of the 32nd Annual Meeting of the Berkeley Linguistics Society (BLS 32)*, ed. by Zhenya Antić, Charles B. Chang, Clare S. Sandy and Maziar Toosarvandani, Berkeley, CA: Berkeley Linguistics Society, pp. 47–58.
- Fortin, Catherine. 2007. Indonesian sluicing and verb phrase ellipsis: Description and explanation in a Minimalist framework. Ph.D. dissertation, University of Michigan.
- Fox, Danny. 1999. Reconstruction, binding theory, and the interpretation of chains. *Linguistic Inquiry* 30: 157–196.
- Gallego, Ángel. 2017. Remark on the EPP in labeling theory: Evidence from Romance. *Syntax* 20: 384–399.

- Gallego, Ángel and Juan Uriagereka. 2007a. Conditions on sub-extraction. In: *Coreference, Modality, and Focus*, ed. by Luis Eguren and Olga Fernández-Soriano, Amsterdam: John Benjamins, pp. 45–70.
- Gallego, Ángel and Juan Uriagereka. 2007b. Sub-extraction from subjects: A phase theory account. In: *Romance Linguistics 2006*, ed. by José Camacho, Nydia Flores-Ferrán, Liliana Sánchez, Viviane Déprez and María José Cabrera, Amsterdam: John Benjamins, pp. 155–168.
- Georgi, Doreen. 2014. Opaque interactions of Merge and Agree: On the nature and order of elementary operations. Ph.D. dissertation, Universität Leipzig.
- Giannakidou, Anastasia and Hedde Zeijlstra. 2017. The landscape of negative dependencies: Negative concord and n-words. In: *The Wiley Blackwell Companion to Syntax, 2nd edition, Vol. IV*, ed. by Martin Everaert and Henk van Riemsdijk, Hoboken, NJ: Wiley, pp. 2099–2136.
- Gibson, Edward and Tessa Warren. 2004. Reading-time evidence for intermediate linguistic structure in long-distance dependencies. *Syntax* 7: 55–78.
- Giorgi, Alessandra and Fabio Pianesi. 1996. Verb movement in Italian and syncretic categories. *Probus* 8: 137–160.
- Giorgi, Alessandra and Fabio Pianesi. 1997. *Tense and Aspect: From Semantics to Morphosyntax*. Oxford: Oxford University Press.
- Grano, Thomas and Howard Lasnik. 2018. How to neutralize a finite clause boundary: Phase theory and the grammar of bound pronouns. *Linguistic Inquiry* 49: 465–499.
- Grohmann, Kleanthes. 1997. German superiority. *Groninger Arbeiten zur Germanistischen Linguistik* 40: 97–107.
- Guilfoyle, Eithne, Henrietta Hung and Lisa Travis. 1992. Spec of IP and Spec of VP: Two subjects in Austronesian languages. *Natural Language and Linguistic Theory* 10: 375–414.
- Harbert, Wayne and Maher Bahloul. 2002. Postverbal subjects and the theory of agreement. In: *Themes in Arabic and Hebrew Syntax*, ed. by Jamal Ouhalla and Ur Shlonsky, Dordrecht: Kluwer, pp. 45–70.
- Harizanov, Boris. 2019. Head movement to specifier positions. *Glossa* 4: 140.
- Harizanov, Boris and Vera Griбанова. 2019. Whither head movement? *Natural Language and Linguistic Theory* 37: 461–522.
- Harley, Heidi. 2017. The “bundling” hypothesis and the disparate functions of little v. In: *The Verbal Domain*, ed. by Roberta D’Alessandro, Irene Franco and Ángel Gallego, Oxford: Oxford University Press, pp. 3–28.
- Harwood, William. 2015. Being progressive is just a phase: Celebrating the uniqueness of progressive aspect under a phase-based analysis. *Natural Language and Linguistic Theory* 33: 523–573.
- Henry, Alison. 2012. Phase edges, quantifier float and the nature of (micro-)variation. *Iberia* 4: 23–39.
- Hsu, Brian. 2016. Syntax-prosody interactions in the clausal domain: Head movement and coalescence. Ph.D. dissertation, University of Southern California, Los Angeles, CA.
- Hsu, Brian. 2021. Coalescence: A unification of bundling operations in syntax. *Linguistic Inquiry* 52: 39–87.
- Jeoung, Helen. 2018. Optional elements in Indonesian morphosyntax. Ph.D. dissertation, University of Pennsylvania, Philadelphia, PA.

- Kayne, Richard. 1994. *The Antisymmetry of Syntax*. Cambridge, MA: MIT Press.
- Kayne, Richards. 1989. Facets of Romance past participle agreement. In: *Dialect Variation and the Theory of Grammar*, ed. by Paola Benincà, Dordrecht: Foris, pp. 85–103.
- Keine, Stefan. 2020a. Locality domains in syntax: Evidence from sentence processing. *Syntax* 23: 105–151.
- Keine, Stefan. 2020b. *Probes and Their Horizons*. Cambridge, MA: MIT Press.
- Korsah, Sampson and Andrew Murphy. 2020. Tonal reflexes of movement in Asante Twi. *Natural Language and Linguistic Theory* 38: 827–885.
- Kotek, Hadas. 2014. Composing questions. Ph.D. dissertation, MIT, Cambridge, MA.
- Kotek, Hadas. 2019. *Composing Questions*. Cambridge, MA: MIT Press.
- Kratzer, Angelika and Lisa Selkirk. 2007. Phase theory and prosodic spellout: The case of verbs. *The Linguistic Review* 24: 93–135.
- Lahiri, Utpal. 2002. On the proper treatment of “expletive *Wh*” in Hindi. *Lingua* 112: 501–540.
- Larson, Richard. 1988. On the double object construction. *Linguistic Inquiry* 19: 335–391.
- Larson, Richard. 2004. Sentence-final adverbs and “scope”. In: *Proceedings of the 34th North East Linguistic Society (NELS 34)*, ed. by Keir Moulton and Matthew Wolf, Amherst, MA: GLSA, pp. 23–43.
- Lechner, Winfried. 2003. Phrase structure paradoxes, movement and ellipsis. In: *The Interfaces: Deriving and Interpreting Omitted Structures*, ed. by Kerstin Schwabe and Susanne Winkler, Amsterdam: John Benjamins, pp. 177–204.
- Legate, Julie Anne. 2003. Some interface properties of the phase. *Linguistic Inquiry* 34: 506–516.
- Legate, Julie Anne. 2011. Under-inheritance, Handout of talk at NELS 42, accessible at: <https://www.ling.upenn.edu/~jlegate/nels11h.pdf>.
- Legate, Julie Anne. 2014. *Voice and v: Lessons from Acehnese*. Cambridge, MA: MIT Press.
- Macdonald, Roderick Ross and Soenjono Darjowidjojo. 1967. *A Student’s Reference Grammar of Modern Formal Indonesian*. Washington, D.C.: Georgetown University Press.
- Manetta, Emily. 2010. *Wh*-expletives in Hindi-Urdu: The vP phase. *Linguistic Inquiry* 41: 1–34.
- Manetta, Emily. 2011. *Peripheries in Kashmiri and Hindi-Urdu: The Syntax of Discourse-Driven Movement*. Amsterdam: John Benjamins.
- Manzini, Rita. 1994. Locality, Minimalism, and parasitic gaps. *Linguistic Inquiry* 25: 481–508.
- Marfo, Charles. 2005a. Akan focus and topic constructions and the prosody-syntax interface. *Journal of West African Languages* 32: 45–59.
- Marfo, Charles. 2005b. Aspects of Akan grammar and the phonology-syntax interface. Ph.D. dissertation, University of Hong Kong.
- Martinović, Martina. 2015. Feature geometry and head-splitting: Evidence from the morphosyntax of the Wolof clausal periphery. Ph.D. dissertation, University of Chicago, Chicago, IL.
- Martinović, Martina. 2019. Feature geometry and head-splitting in the wolof clausal periphery, Ms., McGill University.
- McCloskey, James. 2000. Quantifier float and *wh*-movement in an Irish English. *Linguistic Inquiry* 31: 57–84.
- McGinnis, Martha. 1998. Locality in A-movement. Ph.D. dissertation, MIT, Cambridge, MA.

- Mendes, Gesoel and Rodrigo Ranero. 2021. Chain reduction via substitution: Evidence from Mayan. *Glossa* 6: 10.
- Miyagawa, Shigeru. 2017. *Agreement Beyond Phi*. Cambridge, MA: MIT Press.
- Müller, Gereon. 2004. Phrase impenetrability and wh-intervention. In: *Minimality Effects in Syntax*, ed. by Arthur Stepanov, Gisbert Fanselow and Ralf Vogel, Berlin: Mouton de Gruyter, pp. 289–325.
- Müller, Gereon. 2010. On deriving CED effects from the PIC. *Linguistic Inquiry* 41: 35–82.
- Müller, Gereon. 2011. *Constraints on Displacement: A Phase-Based Approach*. Amsterdam: John Benjamins.
- Nissenbaum, Jonathan. 2000. Investigations of covert phrase movement. Ph.D. dissertation, MIT, Cambridge, MA.
- Pesetsky, David. 1995. *Zero Syntax: Experiencers and Cascades*. Cambridge, MA: MIT Press.
- Polinsky, Maria. 2003. Non-canonical agreement is canonical. *Transactions of the Philological Society* 101: 279–312.
- Polinsky, Maria and Eric Potsdam. 2001. Long-distance agreement and topic in Tsez. *Natural Language and Linguistic Theory* 19: 583–646.
- Poole, Ethan. 2017. Movement and the semantic type of traces. Ph.D. dissertation, University of Massachusetts, Amherst, MA.
- Poole, Ethan. 2022. Improper case, *Natural Language and Linguistic Inquiry*, <https://doi.org/10.1007/s11049-022-09541-6>.
- Preminger, Omer. 2014. *Agreement and Its Failures*. Cambridge, MA: MIT Press.
- Pylkkänen, Liina. 2002. Introducing arguments. Ph.D. dissertation, MIT, Cambridge, MA.
- Pylkkänen, Liina. 2008. *Introducing Arguments*. Cambridge, MA: MIT Press.
- Rackowski, Andrea and Norvin Richards. 2005. Phase edge and extraction. *Linguistic Inquiry* 36: 565–599.
- Rivero, María Luisa. 1994. Clause structure and V-movement in the languages of the Balkans. *Natural Language and Linguistic Theory* 12: 63–120.
- Rizzi, Luigi. 1990. *Relativized Minimality*. Cambridge, MA: MIT Press.
- Rizzi, Luigi. 2006. On the form of chains: Criterial positions and ECP effects. In: *Wh-Movement: Moving On*, ed. by Lisa Cheng and Norbert Corver, Cambridge, MA: MIT Press, pp. 97–133.
- Rizzi, Luigi. 2010. On some properties of criterial freezing. In: *The Complementizer Phase: Subjects and Operators*, ed. by E. Phoevos Panagiotidis, Oxford: Oxford University Press, pp. 17–32.
- Rizzi, Luigi. 2015. Cartography, criteria, and labeling. In: *Beyond Functional Sequence: The Cartography of Syntactic Structures, Vol. 10*, ed. by Ur Shlonsky, Oxford: Oxford University Press, pp. 314–338.
- Roberts, Ian. 1991. Excorporation and minimality. *Linguistic Inquiry* 22: 209–218.
- Roberts, Ian. 1994. Two types of head movement in Romance. In: *Verb Movement*, ed. by David Lightfoot and Norbert Hornstein, Cambridge: Cambridge University Press, pp. 207–242.
- Roberts, Ian. 2010. *Agreement and Head Movement: Clitics, Incorporation, and Defective Goals*. Cambridge, MA: MIT Press.
- Saddy, Douglas. 1991. WH scope mechanisms in Bahasa Indonesia. In: *More Papers on Wh-Movement*, ed. by Lisa Cheng and Hamida Demirdache, Cambridge, MA: MITWPL, pp. 183–218.

- MIT Working Papers in Linguistics 15.
- Sato, Yosuke. 2012. Successive cyclicity at the syntax-morphology interface: Evidence from Standard Indonesian and Kendal Javanese. *Studia Linguistica* 66: 32–57.
- Sauerland, Uli. 2003. Intermediate adjunction with A-movement. *Linguistic Inquiry* 34: 308–314.
- Soh, Hooi Ling. 1998. Certain restrictions on A-bar movement in Malay. In: *Recent Papers in Austronesian Linguistics. Proceedings of the Third and Fourth Meetings of the Austronesian Formal Linguistics Association (AFLA)*, ed. by Matthew Pearson, Los Angeles, CA: UCLA Department of Linguistics, pp. 295–308.
- Soh, Hooi Ling and Hiroki Nomoto. 2009. Progressive aspect, the verbal prefix *men-*, and stative sentences in Malay. *Oceanic Linguistics* 48: 148–171.
- Soh, Hooi Ling and Hiroki Nomoto. 2011. The Malay verbal prefix *men-* and the unergative/unaccusative distinction. *Journal of East Asian Linguistics* : 77–106.
- Sportiche, Dominique. 1988. A theory of floating quantifiers and its corollaries for constituent structure. *Linguistic Inquiry* 19: 425–450.
- Takahashi, Daiko. 1993. Movement of wh-phrases in Japanese. *Natural Language and Linguistic Theory* 11: 655–678.
- Takahashi, Daiko. 1994. Minimality of movement. Ph.D. dissertation, University of Connecticut, Storrs.
- Takahashi, Masahiko. 2010. Case, phases, and nominative/accusative conversion in Japanese. *Journal of East Asian Linguistics* 19: 319–355.
- Takahashi, Masahiko. 2011. Some consequences of Case-marking in Japanese. Ph.D. dissertation, University of Connecticut, Storrs.
- Thráinsson, Höskuldur. 1996. On the (non-)universality of functional categories. In: *Minimal Ideas: Syntactic Studies in the Minimalist Framework*, ed. by Werner Abraham, Samuel Epstein, Höskuldur Thráinsson and Jan-Wouter Zwart, Amsterdam: John Benjamins, pp. 253–281.
- Travis, Lisa. 1984. Parameters and effects of word order variation. Ph.D. dissertation, MIT, Cambridge, MA.
- Van Urk, Coppe. 2015. A uniform syntax for phrasal movement: A case study of Dinka Bor. Ph.D. dissertation, MIT, Cambridge, MA.
- Van Urk, Coppe. 2016. On the distribution of reflexes of successive cyclicity, Handout of talk at the Brussels Conference on Generative Linguistics (BCGL) 9, accessible at: <http://webpace.qmul.ac.uk/cvanurk/PhaseTheoryTalk.pdf>.
- Van Urk, Coppe. 2018. Pronoun copying in Dinka Bor and the Copy Theory of Movement. *Natural Language and Linguistic Theory* 36: 937–990.
- Van Urk, Coppe. 2020a. How to detect a phase. In: *Recent Developments in Phase Theory*, ed. by Jeroen van Craenenbroeck, Cora Pots and Tanja Temmerman, Berlin: de Gruyter, pp. 89–130.
- Van Urk, Coppe. 2020b. Successive cyclicity and the syntax of long-distance dependencies. *Annual Review of Linguistics* 6: 111–130.
- Van Urk, Coppe and Norvin Richards. 2015. Two components of long-distance extraction: Successive cyclicity in Dinka. *Linguistic Inquiry* 46: 113–155.
- Wiltschko, Martina. 1997. Scrambling, D-linking and superiority in German. *Groninger Arbeiten zur Germanistischen Linguistik* 41: 107–142.

Zeijlstra, Hedde. 2004. *Sentential Negation and Negative Concord*. Utrecht: LOT.

Zeijlstra, Hedde. 2012. There is only one way to agree. *The Linguistic Review* 29: 491–539.